

48 Series Operator's Manual



SYNRAD[®]

A Novanta Company

4600 Campus Place
Mukilteo, WA 98275

1.800.SYNRAD1

tel 1.425.349.3500

fax 1.425.349.3667

e-mail synrad@synrad.com

web www.synrad.com

48 Series Operator's Manual

Model 48-1

Model 48-2

Model 48-5

Version 9.5

SYNRAD is a registered trademark of Novanta Corporation. ©Novanta Corporation 2018. All Rights Reserved. No reproduction without written authorization.

DATE: March 2019

Table of contents

Introduction 1

Introduction5
Series 48™ Trademark, Warranty & Copyright information6
Guidelines & Content10
Unpacking/packing, storage/shipping, mounting, connecting, cooling10
Series 48 nomenclature12

Laser Safety 2

Laser Safety14
Hazard Information15
Other hazards18
Disposal18
Series 48-1 label locations19
Series 48-2 label locations20
Series 48-5 label locations21
Agency compliance22

Operation 3

Controls and Indicators27
48-1/48-2 front panel27
48-1/48-2 rear panel28
Side panel29
48-5 front panel30
48-5 rear panel31

Technical Reference 4

Technical reference summary34
Technical overview35
Introduction35
Plasma section35
Controlling Laser Power36
Optical resonator36
Fault shutdown conditions37
Cooling37
Cooling38
Setting coolant temperature38
Duo-Lase® operation (48-5)41
Optical setup41
Control signals44
Operating modes49
UC-2000 Universal Laser Controller50
Continuous wave (CW) operation51

Table of contents

Technical Reference 4

- DB-9 connections53
- User I/O connections.....55
- Sample DB-9 Connector I/O circuits58
- Sample output circuits59
- Integrating Series 48™ safety features61
- Remote keyswitch functions.....61
- Remote interlock functions62
- Water-cooled connections.....64
- Water-cooled connections.....65
- Model 48-1 general specifications67
- Model 48-2 general specifications69
- Model 48-5 general specifications71
- Model 48-5 general specifications72
- Technical Drawings.....73

Maintenance & Troubleshooting 5

- Maintenance and Troubleshooting82
- Introduction82
- Maintenance83
- Disabling the Series 48™ laser.....83
- Daily inspections83
- Storage/shipping.....84
- Coolants.....84
- Cleaning guidelines.....86
- Cleaning optics87
- Troubleshooting88
- Troubleshooting Introduction.....88
- Resetting faults89
- Keyswitch lasers.....89
- Status LEDs94
- Beam delivery optics.....95

Appendix A

- Appendix.....96

Index

- Index 101

Introduction

1

Introduction

- Series 48™ Trademark, Copyright & Warranty information
- Series 48 guidelines and contents description
- Series 48 Nomenclature

Warning Serious personal injury



Remote interlock faults are not latched on OEM lasers. Clearing the fault condition re-enables the RDY indicator and the laser will be enabled five seconds after the SHT indicator is lit and a PWM Command signal is applied.

Because exposure to CO₂ laser radiation in the (9-11) μm range can inflict severe corneal injuries and seriously burn human tissue, the OEM or System Integrator must ensure that appropriate safeguards are in place to prevent unintended lasing.

Caution Possible Equipment Damage



SYNRAD does not recommend vertical or head down configurations.

Please contact the factory for limitations as a vertical orientation increases the risk of damage to the lasers optics.

A **risk of exposure** to toxic elements may result when certain optical or beam delivery components are damaged. In the event of damage to laser, marking head, or beam delivery optics, contact SYNRAD®, or the optics manufacturer for handling instructions.

If you **operate your laser dirty or dusty environments**, contact SYNRAD about the risks of doing so and precautions you can take to increase the longevity of your laser, marking head, and associated optical components.

Important Note: This Operation Manual explains operation activities related to Series 48™ lasers. If you cannot operate the unit using the information described in this manual, contact SYNRAD® (+1.425.349.3500) or an authorized SYNRAD Distributor.

The Quick Start Guide (QSG) [Quickstart](#) explains how to quickly unpack and assemble Series 48 lasers. Please reference the QSG along with the information within this manual.

Lift the laser only by the mounting feet or baseplate. Do not lift or support the laser by its cooling fittings.

Please reference the Quick Start Guide for unpacking, mounting, and connecting.

Failure to properly package the laser using SYNRAD shipping box and foam/cardboard inserts as shown in Packaging Instructions may void the warranty. Customers may incur additional repair charges due to shipping damage caused by improper packaging.

Before beginning any maintenance or inspections of your Series 48 laser, be sure to completely disable the laser by disconnecting the DC Power cable (or cables) from the rear of the laser.

Introduction

Trademark/copyright information

Series 48™ Trademark, Warranty & Copyright information

SYNRAD® and Series 48™ are registered trademarks of SYNRAD.

All other trademarks or registered trademarks are the property of their respective owners.

2018 by SYNRAD.
All rights reserved.

Introduction

Warranty information

This is to certify that Series 48-1 lasers are guaranteed by SYNRAD® to be free of all defects in materials and workmanship for three years from the date of shipment. Series 48-2 and 48-5 lasers are guaranteed to be free of all defects in materials and workmanship for a period of one year from the date of shipment. This warranty does not apply to any defect caused by negligence, misuse (including environmental factors), accident, alteration, or improper maintenance. This includes, but is not limited to, damage due to corrosion, condensation, or failing to supply properly conditioned purge gas.

We request that you examine each shipment within 10 days of receipt and inform SYNRAD of any shortage or damage. If no discrepancies are reported, SYNRAD shall assume the shipment was delivered complete and defect-free.

If, within one year from the date of purchase, any part of the Series 48 laser should fail to operate, contact the SYNRAD Customer Service department at 1.800.SYNRAD1 (outside the U.S. call 1.425.349.3500) and report the problem. When calling for support, please be prepared to provide the date of purchase, model number and serial number of the unit, and a brief description of the problem. When returning a unit for service, a Return Authorization (RA) number is required; this number must be clearly marked on the outside of the shipping container in order for the unit to be properly processed. If replacement parts are sent to you, then you are required to send the failed parts back to SYNRAD for evaluation unless otherwise instructed.

If your Series 48 laser fails within the first 45 days after purchase, SYNRAD will pay all shipping charges to and from SYNRAD when shipped as specified by SYNRAD Customer Service. After the first 45 days, SYNRAD will continue to pay for the costs of shipping the repaired unit or replacement parts back to the customer from SYNRAD. The customer, however, will be responsible for shipping charges incurred when sending the failed unit or parts back to SYNRAD or a SYNRAD Authorized Distributor. In order to maintain your product warranty and to ensure the safe and efficient operation of your Series 48 laser, only authorized SYNRAD replacement parts can be used. This warranty is void if any parts other than those provided by SYNRAD are used.

SYNRAD and SYNRAD Authorized Distributors have the sole authority to make warranty statements regarding SYNRAD products. SYNRAD and its Authorized Distributors neither assumes nor authorizes any representative or other person to assume for us any other warranties in connection with the sale, service, or shipment of our products. SYNRAD reserves the right to make changes and improvements in the design of our products at any time without incurring any obligation to make equivalent changes in products previously manufactured or shipped. Buyer agrees to hold SYNRAD harmless from any and all damages, costs, and expenses relating to any claim arising from the design, manufacture, or use of the product, or arising from a claim that such product furnished buyer by SYNRAD, or the use thereof, infringes upon any Patent, foreign or domestic.

Introduction

Sales, Application, & Support

SYNRAD Sales & Support

SYNRAD Headquarters

SYNRAD® worldwide headquarters are located north of Seattle in Mukilteo, Washington. U.S.A. Our mailing address is:

SYNRAD
4600 Campus Place
Mukilteo, WA 98275
U.S.A.

Phone us at: 1.800.SYNRAD1 (1.800.796.7231)

Outside the U.S.: +1.425.349.3500

Fax: +1.425.349.3667

E-mail: synrad@synrad.com

web: www.synrad.com

Sales and Applications

SYNRAD Regional Sales Managers work with customers to identify and develop the best CO₂ laser solution for a given application. Because they are familiar with you and your laser application, use them as a first point of contact when questions arise. Regional Sales Managers also serve as the liaison between you and our Applications Lab in processing material samples per your specifications. To speak to the Regional Sales Manager in your area, call SYNRAD at 1.800.SYNRAD1.

Customer Service

For assistance with order or delivery status, service status, or to obtain a Return Authorization (RA) number, contact SYNRAD at 1.800.SYNRAD1 and ask to speak to a Customer Service representative, or you can email us by sending a message to customercare@synrad.com.

Technical Support

SYNRAD Regional Sales Managers are able to answer many technical questions regarding the installation, use, troubleshooting, and maintenance of our products. In some cases, they may transfer your call to a Laser, Marking Head, or Software Support Specialist. You may also e-mail questions to the Technical Support Group by sending your message to customercare@synrad.com.

Reference materials

Your Regional Sales Manager can provide reference materials including Outline & Mounting drawings, Operator's Manuals, Technical Bulletins, and Application Newsletters. Most of these materials are also available directly from SYNRAD web site at <http://www.synrad.com>.

Introduction

European headquarters

European Headquarters

For assistance in Europe, contact SYNRAD® European subsidiary, SYNRAD Europe, at:

©Novanta Distribution (USD) GmbH
Parkring 57-59
85748 Garching bei München, Germany

Phone: +49 89 31707-0

Fax: +49 (0) 89 31707-222

E-mail: EMEA-service@novanta.com

web: www.synrad.com

Introduction

Guidelines & Content Description

Guidelines & Content

See the drawings within this Operation Manual when installing and operating your Series 48™ laser.

- Unpacking/Packing, Storage/Shipping, Mounting, Connecting, Cooling
- Series 48 nomenclature/features

Unpacking/packing, storage/shipping, mounting, connecting, cooling

SYNRAD® recommends saving all of the laser's original packaging. It's unique design assists in preventing damage to your laser during storage, relocation and/or shipping.

Reference our Quick Start Guide Series at [Synrad.com](https://www.synrad.com). Additional information can also be found in the Technical Reference chapter within this manual.

Contents description

Each item below is also listed in tables that follow:

SYNRAD® OEM Series 48™ Laser – for cutting, welding, drilling, and marking a wide variety of products and materials.

Customer Communication Flier Series 48– Instead of the laser manual CD, please follow the instructions for our latest laser manual(s) located here: <https://www.synrad.com/resources/libraries/manuals>

Mounting kit (Keypress models only) – Contains components to mount the laser and also includes a DB-9 connector and cover to replace the factory jumper plug when integrating Series 48 laser signals into your control system.

Spare Fuse – Fuses protect Series 48 internal circuitry. A 10 A fuse is included with 48-1 lasers, a 20 A fuse with 48-2 lasers, and two 20 A fuses are shipped with 48-5 lasers.

Final Test Report (not shown) – Contains data collected during the laser's final pre-shipment test.

Cooling Kit (water-cooled lasers only) – (48-1/48-2) includes quick-disconnect inlet and outlet cooling manifolds, extra 1/4" union elbows, extra straight 1/8 in NPT to 1/4 in tube fittings, and 20 feet of 1/4 in O.D. black polyethylene tubing. (48-5) – includes quick-disconnect inlet and outlet cooling manifolds, extra 1/4 in union elbows, extra straight 1/4 in NPT to 3/8 in tube fittings, and 20 feet of 3/8 in O.D. black polyethylene tubing.

Introduction

Guidelines & Content Description

SYNRAD® CO₂
Web Flier



Spare Fuse(s)



Cooling Kit - water
cooled lasers only
(48-1/48-2 kit shown)

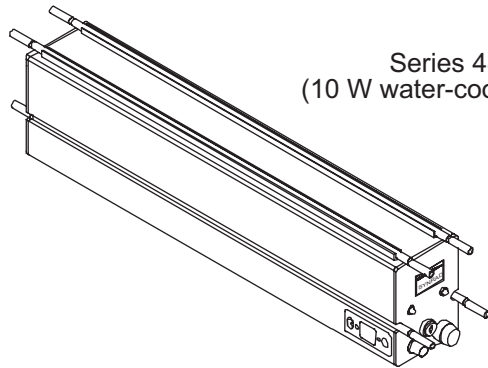
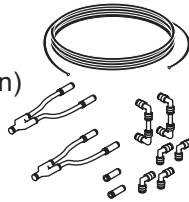

Series 48™ Laser
(10 W water-cooled laser shown)

Figure 1-1 Series 48™ ship kit contents.

Table 1-1 Series 48 ship kit contents.

Shipping Box Contents	Qty	Shipping Box Contents	Qty
Series 48 Laser.....	1	Mounting Bolts	(Not Standard)
Customer communication flier	1	Cooling Kit	(As Required)
Spare Fuses	(As Required)	Final Test Report (not shown)	1

Maximum torque (48-1) 0.41 Nm or 4 in-lb 6-32 screw, (48-2) 0.41 Nm or 4 in-lb 6-32 screw, (48-5) 1.4 Nm or 12.1 in-lb 10-32 screw.

Minimum thread engagement should be 5 mm or 0.200 in (48-1 and 48-2 only).

Maximum thread engagement should be (48-1) 7.6 mm or 0.300 in, (48-2) 7.6 mm or 0.300 in, (48-5) .2 mm or 0.125 in,

*Recommend using low-outgassing thread lock adhesive or locking washer.

*Refer to outline and mounting drawing for details.

Introduction

Guidelines & Content Description

Series 48 nomenclature

The Series 48 nomenclature section includes:

- Model numbers
- Series 48 laser versions

The last three characters in the Series 48 model number serve to designate the functional category, cooling method, and model version. The functional category is indicated by either a "K" for Keyswitch or "S" Standard (OEM) for OEM models. The next letter indicates the cooling method: "W" for water-cooled units, "A" for air-cooled lasers (where the customer must provide the proper cooling via fans or blowers). The last letter in the model number indicates the current model version "N". For example, the model number 48-1 KWN designates the Series 48 laser as a Keyswitch, water-cooled version N.

Introduction

Features & Nomenclature

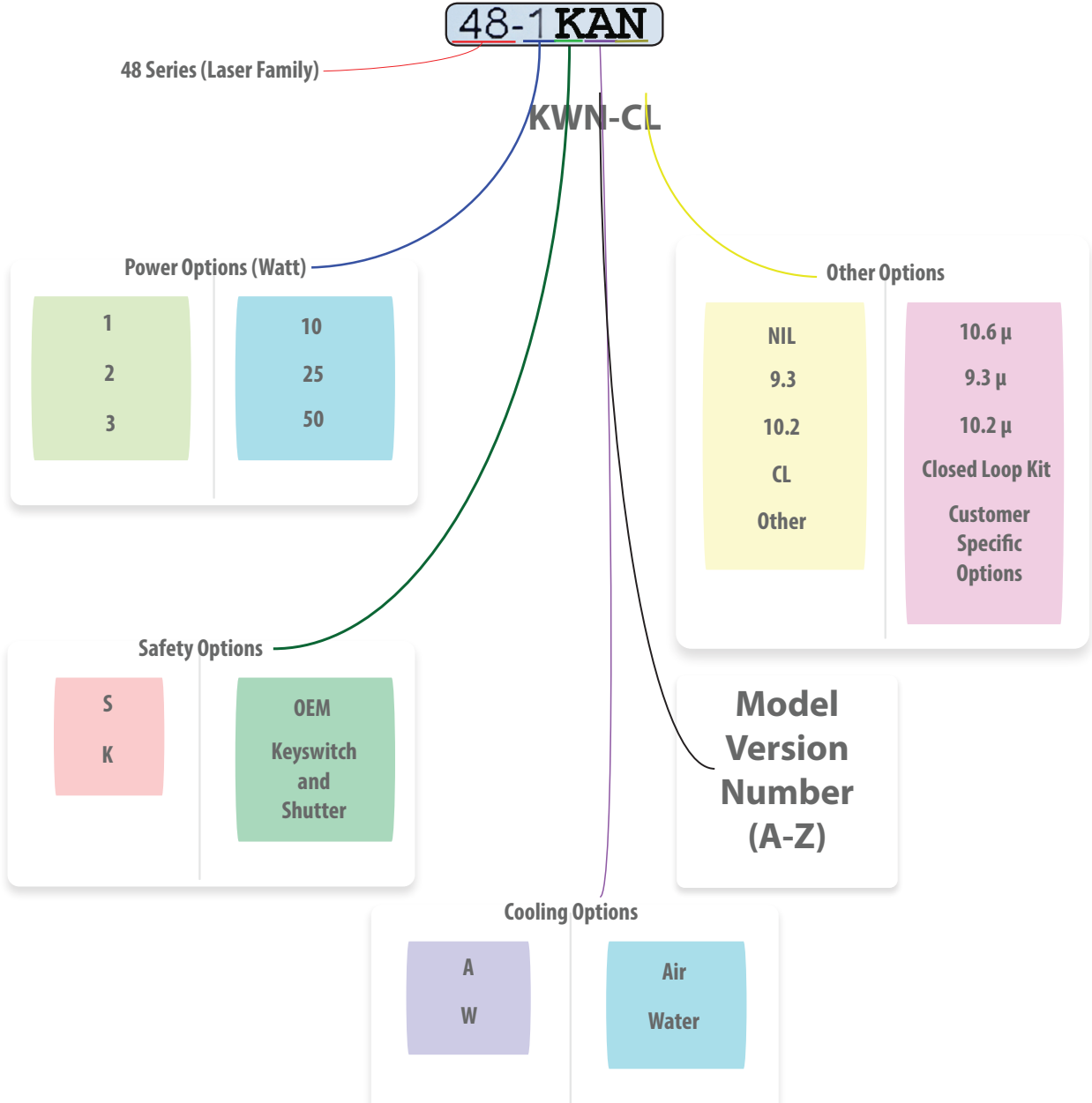

Figure 1-2 Anatomy of a model number.

Laser Safety

2

Laser Safety

- Hazard Information – includes equipment label terms and hazards, please familiarize yourself with all definitions and their significance.
- General & Other Hazards – provides important information about the hazards and unsafe practices that could result in death, severe injury, or product damage.
- Disposal – information on your 48 series laser parts and/or components as they pertain to disposal.
- Additional safety Information – describes how to find additional information about your 48 series laser.
- Compliance – explains in the subsections therein applicable and appropriate regulation information.

Note: Read the entire safety section. This will ensure you are familiar with the hazards and warnings prior to starting.

Warning **Serious** **personal** **injury**



Safety Data Sheets (SDS) for materials processed should be evaluated and the adequacy of provisions for fume extraction, filtering, and venting should be carefully considered.

This Class 4 CO₂ laser product emits invisible infrared laser radiation in the 9.3–10.6 μm wavelength band.

Because direct or diffuse laser radiation can inflict severe corneal injuries, always wear eye protection when in the same area as an exposed laser beam.

Do not allow the laser beam to contact a person!

This product emits an invisible laser beam that is capable of seriously burning human tissue.

Always be aware of the beam's path and always use a beam block while testing. Assure you understand target material.

Laser Safety

Hazard Information

Hazard information includes terms, symbols, and instructions used in this manual or on the equipment to alert both operating and service personnel to the recommended precautions in the care, use, and handling of Class 4 laser equipment.

Terms

Certain terms are used throughout this manual or on the equipment labels. Please familiarize yourself with their definitions and significance.





Parameter	Description
	<p>WARNING: Alerts operator of serious dangers, hazardous radiation, hazardous voltages, vapor hazard, & reflective dangers. Potential & Imminent hazards which, if not avoided, could result in death or serious injury.</p>
	<p>DANGER: Alerts operator of lifting dangers. Hazards which, if not avoided, could result in minor or moderate injury.</p>
	<p>CAUTION: Alerts operator of equipment dangers. Potential hazards or unsafe practices which, if not avoided, may result in product damage.</p>
	<p>IMPORTANT NOTES & TIPS: Alerts operator of Content specific information and/or recommendations. If not followed may lead to inconveniences such as rail assembly which could lead to re-work.</p>

Figure 2-1 Labeling terms and definitions.

Warning
Serious personal injury

For laser systems being used or sold within the U.S.A., customers should refer to and follow the laser safety precautions described American National Standards Institute (ANSI) document Z136.1-2014, Safe Use of Lasers.

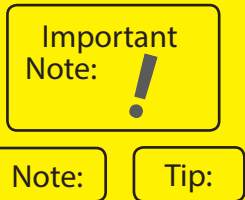
For laser systems being used or sold outside the U.S.A., customers should refer to and follow the laser safety precautions described in European Normative and International Electrotechnical Commission documents IEC/TR 60825-14:2014, Safety of Laser Products – §14: A User's Guide.

Laser Safety

Hazard Information (Continued)

Following are descriptions of hazards and unsafe practices that could result in death, severe injury, or product damage. Specific warnings and cautions not appearing in this section are found throughout the manual.

Warning **Serious** **personal** **injury**



Enclose the beam path whenever possible. Exposure to direct or diffuse CO₂ laser radiation can seriously burn human or animal tissue, which may cause permanent damage.

This product is not intended for use in explosive, or potentially explosive, atmospheres.

Materials processing with a laser can generate air contaminants such as vapors, fumes, and/or particles that may be noxious, toxic, or even fatal.

Safety Data Sheets (SDS) for materials being processed should be thoroughly evaluated and the adequacy of provisions for fume extraction, filtering, and venting should be carefully considered. Review the following references for further information on exposure criteria:

Review the following references for further information on exposure criteria:

ANSI Z136.1-2007, *Safe Use of Lasers*, section 7.3.

U.S. Government's Code of Federal Regulations: 29 CFR 1910, Subpart Z.

Threshold Limit Values (TLV's) published by the American Conference of Governmental Industrial Hygienists (ACGIH).

It may be necessary to consult with local governmental agencies regarding restrictions on the venting of processing vapors.

The use of aerosol dusters containing difluoroethane causes "blooming", a condition that significantly expands and scatters the laser beam. This beam expansion can affect mode quality and/or cause laser energy to extend beyond the confines of optical elements in the system, possibly damaging acrylic safety shielding. Do not use air dusters containing difluoroethane in any area adjacent to CO₂ laser systems because difluoroethane persists for long time periods over wide areas.

Laser Safety

Hazard Information (Continued)

48 Series lasers should be installed and operated in manufacturing or laboratory facilities by trained personnel only. Due to the considerable risks and hazards associated with the installation and operational use of any equipment incorporating a laser, the operator must follow product warning labels and instructions to the user regarding laser safety. To prevent exposure to direct or scattered laser radiation, follow all safety precautions specified throughout this manual and exercise safe operating practices per ANSI Z136.1-2014, Safe Use of Lasers at all times when actively lasing.

Due to the specific properties of laser light, a unique set of safety hazards that differ from other light sources must be considered. Just like light, lasers can be reflected, refracted, diffracted or scattered.



Figure 2-2 Always wear safety glasses or protective goggles with side shields to reduce the risk of damage to the eyes when operating the laser.

A CO₂ laser is an intense energy source and will ignite most materials under the proper conditions. Never operate the laser in the presence of flammable or explosive materials, gases, liquids, or vapors.

Warning Serious personal injury

“Caution  - The use of controls or adjustments or performance of procedures other than those specified herein may result in hazardous radiation exposure.”



Safe operation of the laser requires the use of an external beam block to safely block the beam from traveling beyond the desired work area. Do not place your body or any combustible object in the path of the laser beam. Use a water-cooled beam dump or power meter, or similar non-scattering, noncombustible material as the beam block. Never use organic material or metals as the beam blocker; organic materials, in general, are apt to combust or melt and metals act as specular reflectors which may create a serious hazard outside the immediate work area.

Laser Safety

Other hazards

The following hazards are typical for this product family when incorporated for intended use: (A) risk of injury when lifting or moving the unit; (B) risk of exposure to hazardous laser energy through unauthorized removal of access panels, doors, or protective barriers; (C) risk of exposure to hazardous laser energy and injury due to failure of personnel to use proper eye protection and/or failure to adhere to applicable laser safety procedures; (D) risk of exposure to hazardous or lethal voltages through unauthorized removal of covers, doors, or access panels; (E) generation of hazardous air contaminants that may be noxious, toxic, or even fatal.

Disposal

This product contains components that are considered hazardous industrial waste. If a situation occurs where the laser is rendered non-functional and cannot be repaired, it may be returned to SYNRAD who, for a fee, will ensure adequate disassembly, recycling and/or disposal of the product.

Additional laser safety information

The SYNRAD web site <http://www.synrad.com/LaserFacts/safetyinfo.html> contains an online laser safety handbook that provides information on (1) Laser Safety Standards for OEM's/System Integrators, (2) Laser Safety Standards for End Users, (3) References and Sources, and (4) Assistance with Requirements.

In addition, the Occupational Safety and Health Administration (OSHA) provides an online Technical Manual located at http://www.osha.gov/dts/osta/otm/otm_iii/otm_iii_6.html. Section III, Chapter 6 and Appendix III are good resources for laser safety information.

Another excellent laser safety resource is the Laser Institute of America (LIA). Their comprehensive web site is located at <http://www.lia.org>.

Laser Safety

Series 48-1 label locations

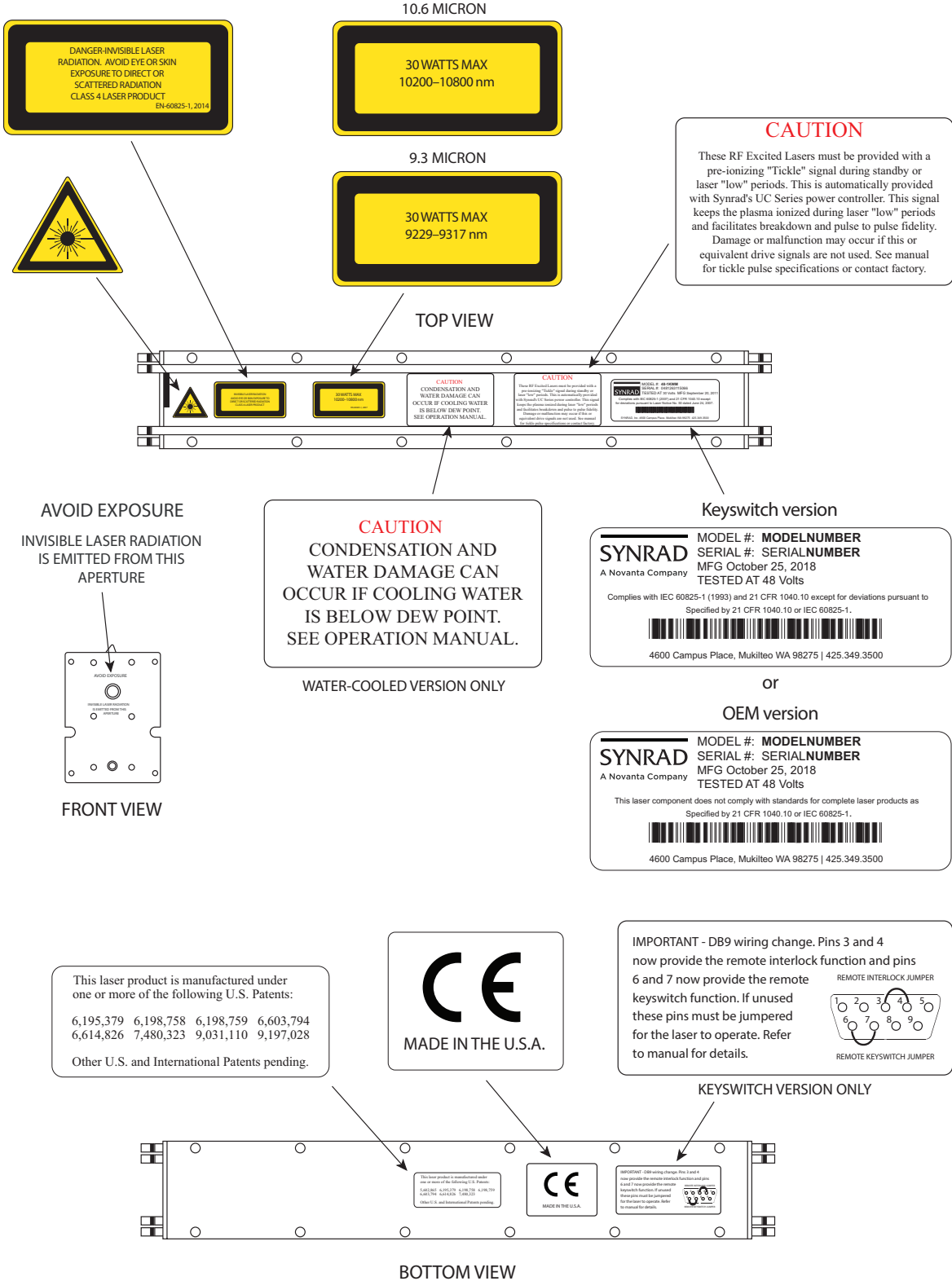

Figure 2-1 Hazard label locations (48-1 example).

Laser Safety

Series 48-2 label locations

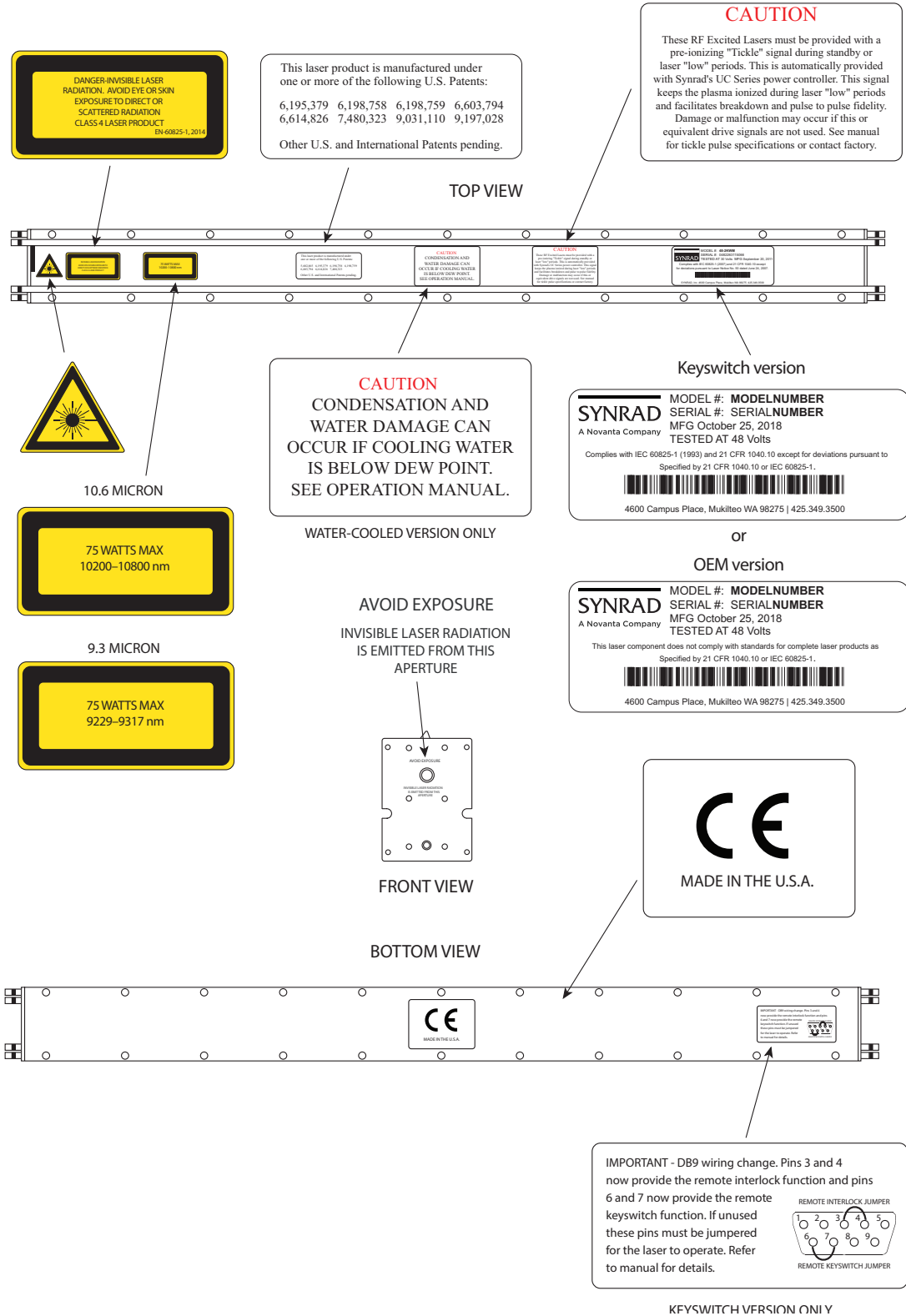

Figure 2-2 Hazard label locations.

Laser Safety

Series 48-5 label locations

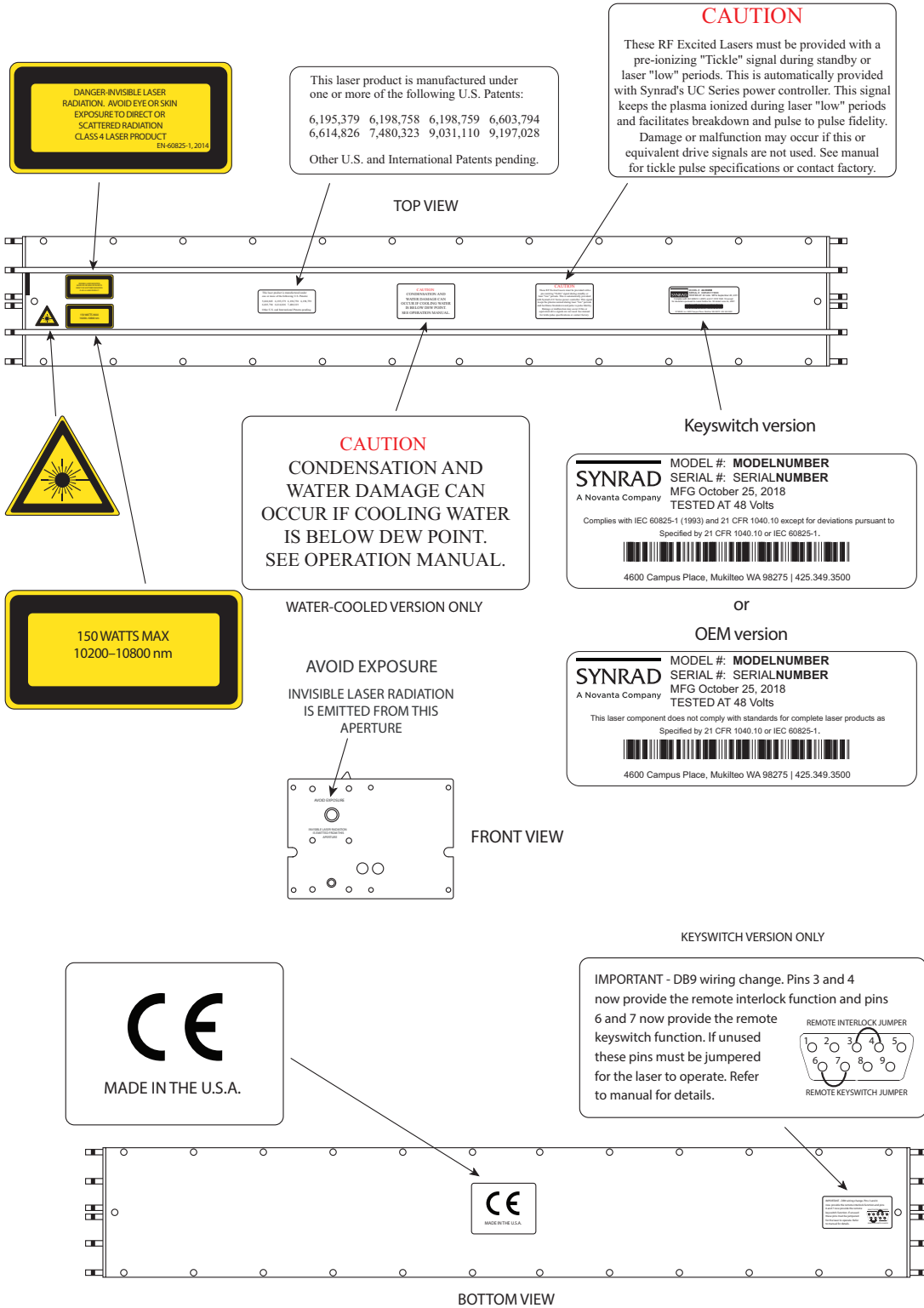

Figure 2-3 Hazard label locations.

Laser Safety

Agency compliance

- Center for Devices and Radiological Health (CDRH) requirements.
- Federal Communications Commission (FCC) requirements.
- European Union (EU) requirements.

SYNRAD lasers are designed, tested, and certified to comply with certain United States (U.S.) and European Union (EU) regulations. These regulations impose product performance requirements related to electromagnetic compatibility (EMC) and product safety characteristics for industrial, scientific, and medical (ISM) equipment. The specific provisions to which systems containing 48 Series lasers must comply are identified and described in the following paragraphs. Note that compliance to CDRH, FCC, and EU requirements depends in part on the laser version selected—Keyswitch or OEM.

In the U.S., laser safety requirements are governed by the Center for Devices and Radiological Health (CDRH) under the auspices of the U.S. Food and Drug Administration (FDA) while radiated emission standards fall under the jurisdiction of the U.S. Federal Communications Commission (FCC). Outside the U.S., laser safety and emissions are governed by European Union (EU) Directives and Standards.

In the matter of CE-compliant laser products, SYNRAD assumes no responsibility for the compliance of the system into which the product is integrated, other than to supply and/or recommend laser components that are CE marked for compliance with applicable European Union Directives.

Because OEM laser products are intended for incorporation as components in a laser processing system, they do not meet all of the Standards for complete laser processing systems as specified by 21 CFR, §1040 or EN 60825-1. SYNRAD assumes no responsibility for the compliance of the system into which OEM laser products are integrated.

Center for Devices and Radiological Health (CDRH) requirements

Product features incorporated into the design of 48 Series lasers to comply with CDRH requirements are integrated as panel controls or indicators, internal circuit elements, or input/output signal interfaces. Specifically, these features include a lase and laser ready indicators, remote interlock for power on/off, a laser aperture shutter switch, and a five-second delay between power on and lasing. Incorporation of certain features is dependent on the laser version (Keyswitch or OEM). Table 1, Class 4 safety features, indicates which features are available on p400 lasers, the type and description of the feature, and if the feature is required by CDRH regulations.

OEM models

48 Series OEM lasers are OEM products intended for incorporation as components in laser processing systems. As supplied by SYNRAD, these lasers do not meet the requirements of 21 CFR, Subchapter J without additional safeguards. In the U.S., the Buyer of these OEM laser components is solely responsible for the assurance that the laser processing system sold to an end user complies with all laser safety requirements before the actual sale of the system. Under CDRH regulations, the Buyer must submit a report to the CDRH prior to shipping the system. In jurisdictions outside the U.S., it is the sole responsibility of the Buyer of these OEM

Laser Safety

components to ensure that they meet all applicable local laser safety requirements. In cases where the Buyer is also the end-user of the OEM laser product, the Buyer/end-user must integrate the laser so that it complies with all applicable laser safety standards as set forth above.

Federal Communications Commission (FCC) Requirements

The United States Communication Act of 1934 vested the Federal Communications Commission (FCC) with the authority to regulate equipment that emits electromagnetic radiation in the radio frequency spectrum. The purpose of the Communication Act is to prevent harmful electromagnetic interference (EMI) from affecting authorized radio communication services. The FCC regulations that govern industrial, scientific, and medical (ISM) equipment are fully described in 47 CFR, §18, §5C.

SYNRAD 48 Series lasers have been tested and found to comply by demonstrating performance characteristics that have met or exceeded the requirements of 47 CFR, §18, §5C for Radiated and Conducted Emissions.

Note: The following FCC information to the user is provided to comply with the requirements of 47 CFR, §18, §5C Information to the user.

Interference Potential

In our testing, SYNRAD has not discovered any significant electrical interference traceable to 48 Series lasers.

System Maintenance

Ensure that all exterior covers are properly fastened in position.

Measures to Correct Interference

If you suspect that your laser interferes with other equipment, take the following steps to minimize this interference:

- 1 Use shielded cables to and from the equipment that is experiencing interference problems.
- 2 Ensure that the laser is properly grounded to the same electrical potential as the equipment or system it is connected to.

FCC caution to the user

The Federal Communications Commission warns the user that changes or modifications of the unit not expressly approved by the party responsible for compliance could void the user's authority to operate the equipment.

Laser Safety

European Union (EU) requirements

RoHS compliance

SYNRAD 48 Series lasers meet the requirements of the European Parliament and Council Directive 2014/35/EU on the Restriction of the Use of Certain Hazardous Substances in Electrical and Electronic Equipment that establishes maximum concentration values for certain hazardous substances in electrical and electronic equipment.

Laser safety standards

Under the Low Voltage Directive, 2014/35/EU, the European Norm (EN) document EN 60825-1:2014 (hereafter referred to as EN 60825-1) including laser diodes and all laser devices defined in ISO 11145 was developed to provide laser safety guidance and includes clauses on Engineering Specifications, Labeling, Other Informational Requirements, Additional Requirements for Specific Laser Products, Classification, and Determination of the Accessible Emission Level. To develop a risk assessment plan/laser safety program for users, see the EN 60825-14:2004 Standard for the safety of laser products that includes clauses on Administrative Policies, Laser Radiation Hazards, Determining the MPE, Associated Hazards, Evaluating Risk, Control Measures, Maintenance of Safe Operation, Incident Reporting and Accident Investigation, and Medical Surveillance.

OEM models

48 Series OEM lasers are OEM products intended for incorporation as components in laser processing systems. As supplied by SYNRAD, these lasers do not meet the requirements of EN 60825-14:2004 without additional safeguards. European Union Directives state that "OEM laser products which are sold to other manufacturers for use as components of any system for subsequent sale are not subject to this Standard, since the final product will itself be subject to the Standard." This means that Buyers of OEM laser components are solely responsible for the assurance that the laser processing system sold to an end-user complies with all laser safety requirements before the actual sale of the system. Note that when an OEM laser component is incorporated into another device or system, the entire machinery installation may be required to conform to EN 60825-14:2004; EN 60204-1:2016, Safety of Machinery; the Machinery Directive, 2006/42/EC; and/or any other applicable Standards and in cases where the system is being imported into the U.S., it must also comply with CDRH regulations.

In cases where the Buyer is also the end-user of the OEM laser product, the Buyer/end-user must integrate the laser so that it complies with all applicable laser safety standards as set forth above. Table 1, Class 4 safety features, summarizes 48 Series product features, indicating the type and description of features and whether those features are required by European Union regulations.

Electromagnetic interference standards

The European Union's Electromagnetic Compatibility (EMC) Directive, 2014/30/EU, is the sole Directive developed to address electromagnetic interference (EMI) issues in electronic equipment. In particular, the Directive calls out European Norm (EN) documents that define the emission and immunity standards for specific product categories. For 48 Series lasers, EN 61000-6-4:2018 defines radiated and conducted RF emission limits while EN 61000-6-2:2016 defines immunity standards for industrial environments.

Laser Safety

Table 2-3 Class 4 safety features.

Feature	Location / Description	Required by:		Available on:
		CDRH	EN60825-1	OEM Series 48
Keyswitch¹	Rear panel control On/Off/Reset Keyswitch controls power to laser electronics. Key cannot be removed from switch in the "On" position.	Yes	Yes	No
Shutter¹ function	Laser control Functions as a beam attenuator to disable RF driver/laser output when closed.	Yes	Yes	No
Shutter indicator	Rear panel indicator (Blue) Illuminates blue to indicate shutter is open.	No	No	Yes
Ready indicator²	Rear panel indicator (Yellow) Indicates that laser has power applied and is capable of lasing.	Yes	Yes	Yes
Lase indicator	Rear panel indicator (Red) Indicates that is actively lasing. Lase LED illuminates when the duty cycle of the Command signal is long enough to produce laser output.	No	No	Yes
Five second delay	circuit element Disables RF driver/laser output for five seconds after Keyswitch is turned to "On" or remote reset/start pulse is applied when Keyswitch is in "On" position.	Yes	No	Yes
Power fail lockout¹	circuit element Disables RF driver/laser output if input power is removed then later reapplied (AC power failure or remote interlock actuation) while Keyswitch is in "On" position.	Yes	Yes	No
Remote Interlock	Rear panel connection Disables RF driver/laser output when a remote interlock switch on an equipment door or panel is opened.	Yes	Yes	Yes
Remote Interlock	Rear panel indicator (Green/Red) Illuminates green when Remote Interlock circuitry is closed indicator Illuminates red when interlock circuitry is open.	No	No	Yes
Over temperature	circuit element Temperature shutdown occurs if temperature of the laser protection tube rises above safe operating limits.	No	No	Yes
Temp indicator	Rear panel indicator (Green/Red) Illuminates green when laser temperature is within operating limits, changing to red when thermal limits are exceeded.	No	No	Yes
Warning labels	Series 48 exterior Labels attached to various external housing locations to warn personnel of potential laser hazards.	Yes	Yes	Yes

1 Keyswitch lasers only.

2 On OEM versions, the Power indicator illuminates and the five (5) second delay begins when DC power is applied to the laser.

Laser Safety

SYNRAD® Series 48 lasers have demonstrated performance characteristics that have met or exceeded the requirements of EMC Directive 2014/30/EU. When integrating SYNRAD Series 48™ OEM lasers, the Buyer and/or integrator of the end system is responsible for meeting all applicable Standards to obtain the CE mark. To aid this compliance process, SYNRAD testing program has demonstrated that Series 48 lasers comply with the relevant requirements of 2014/30/EU, the Electromagnetic Compatibility Directive, as summarized in the table below.

Table 2-4 European Union Directives.

Applicable Standards / Norms

2014/30/EU	Electromagnetic Compatibility Directive
2006/95/EC	Low Voltage Directive
2011/65/EU	RoHS Directive
EN 61010-1	Safety Requirements for Electrical Equipment for Measurement, Control, and Laboratory Use - Part 1: General Requirements
EN 61000-6-4:2007	Radiated Emissions Group 1, Class A
EN 61000-6-4:2007	Conducted Emissions Group 1, Class A
EN 61000-6-2:2005	Electrostatic Discharge Immunity
EN 61000-6-2:2005	RF Electromagnetic Field Immunity
EN 61000-6-2:2005	Electrical Fast Transient/Burst Immunity
EN 61000-6-2:2005	Conducted RF Disturbances Immunity

After a laser or laser processing system has met the requirements of all applicable EU Directives, the product can bear the official compliance mark of the European Union as a Declaration of Conformity.

After a laser or laser processing system has met the requirements of all applicable EU Directives, the product can bear the official compliance mark of the European Union as shown in the figure below and a Declaration of Conformity is provided for the compliant component.

Laser Safety



Declaration of Conformity	
in accordance with ISO / IEC 17050-2:2004	
We,	
Manufacturer's Name:	SYNRAD® A Novanta® Company
Manufacturer's Address:	4600 Campus Place Mukilteo, WA 98275 U.S.A.
Hereby declare under our sole responsibility that the following equipment:	
Product Name:	Series 48™ Laser
Model Number:	48-1KxN; 48-2KxN; 48-5KxN (Keyswitch) 48-1SxN; 48-2KxN; 48-5KxN (*OEM)
Conforms to the following Directive(s) and Standard(s):	
Applicable Directive(s):	2014/30/EU Electromagnetic Compatibility Directive 2014/35/EU Low Voltage Directive 2011/65/EU RoHS Directive
Applicable Standard(s):	
EN 61010-1:2010	Safety Requirements for Electrical Equipment for Measurement, Control, and Laboratory Use - Part 1: General Requirements
EN 60825-1-4:2014	Safety of Laser Products (Keyswitch only)
EN 61000-6-4:2007	Radiated Emissions, Group 1, Class A
EN 61000-6-4:2007	Conducted Emissions, Group 1, Class A
EN 61000-6-2:2005	Electrostatic Discharge Immunity
EN 61000-6-2:2005	RF Electronic Fields Immunity
EN 61000-6-2:2005	Electrical Fast Transient/burst Immunity
EN 61000-6-2:2005	Conducted RF Disturbances Immunity
*OEM lasers do not comply with EN 60825-1:2014, <i>Safety of Laser Products</i> . Buyers of OEM laser products are solely responsible for meeting applicable Directives and Standards for CE compliance and marking.	
Corporate Officer:	European Contact:
	Novanta Distribution (USD) GmbH Parking 57-59 85748 Garching bei München, Germany
Tim Freni, Quality Manager of SYNRAD	
Dated: 3/4/19	
	
	MADE IN THE U.S.A. 900-20976-07 Rev E

Figure 2-5 48 Series Declaration Document.

Operation

3

Use information in this chapter to familiarize yourself with Series 48™ controls and indicators. Reference the Quick Start Guide for the initial startup process.

This chapter contains the following information:

- Controls and indicators – displays and describes exterior controls and indicators on Series 48 Keyswitch and OEM lasers.
- Initial start-up – Reference the appropriate [Quick Start Guide](#) on our website to learn how to start your Series 48 laser while verifying proper operation.

Caution **Possible** **Equipment** **Damage**



Remove the aperture seal before firing the laser. The self-adhesive seal is installed to prevent dust from entering the laser housing during shipment and installation and must be removed before operation. During laser operation, use a gas purge to keep dust and vapor out of the beam path.

Applying PWM Command pulses directly to the laser without first sending tickle pulses for at least two seconds will cause unpredictable laser emission, degrade optical rise time, and may lead to RF Driver failure.

Always assure **inlet water temp is maintained above dew point!**

Operation

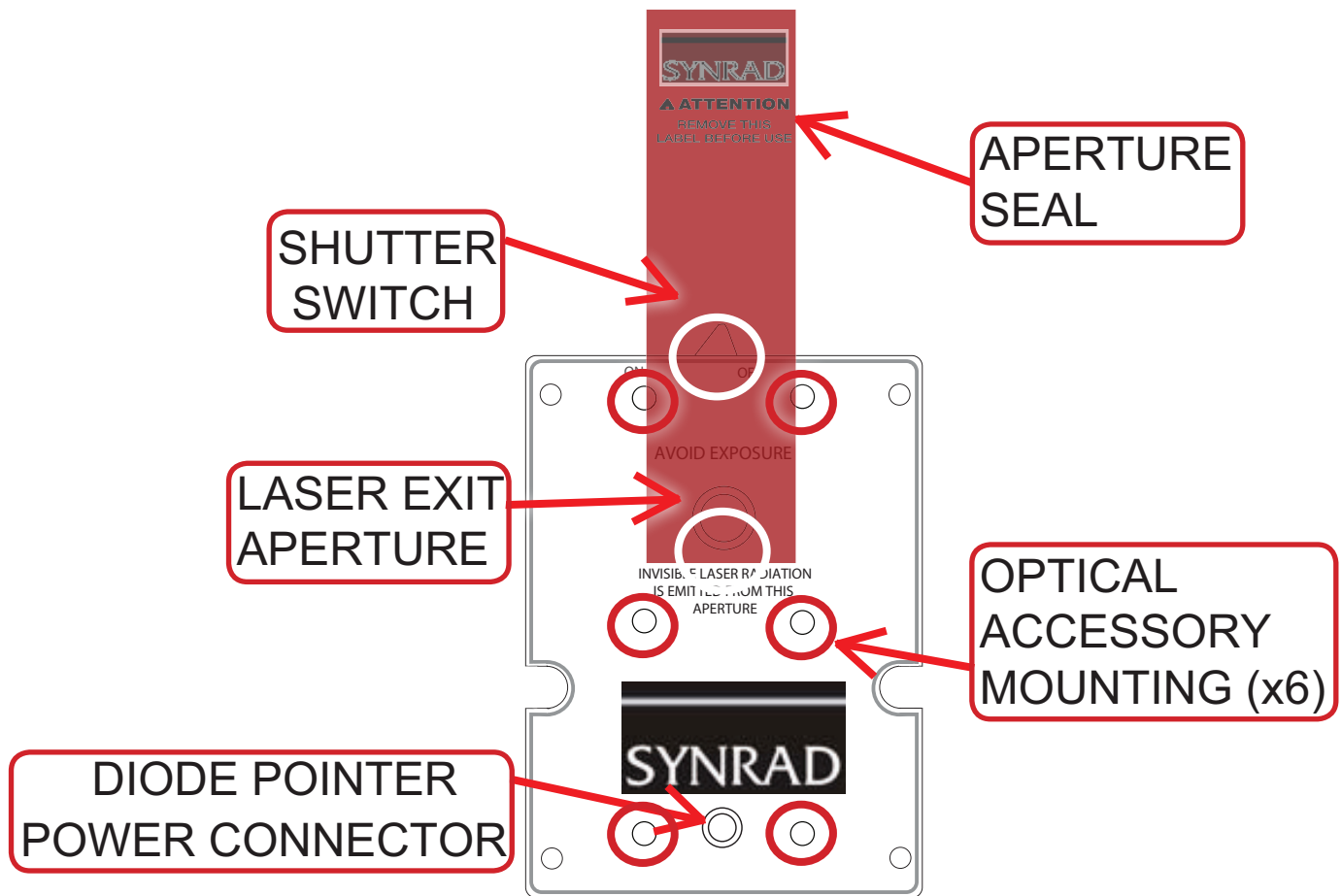

Figure 3-1 48-1/48-2 Front panel controls and indicators.

Controls and Indicators

48-1/48-2 front panel

Aperture Seal – prevents dust from damaging the output coupler during shipping. Remove the red self-adhesive label before applying power to the laser.

Shutter Switch (Keyswitch models only) – manually closes the laser aperture and interrupts power to the RF section(s). Do not use the shutter to partially block the beam or to control output power.

Laser Exit Aperture – provides an opening from which the beam is emitted when lasing.

Optical Accessory Mounting – provides six threaded holes for mounting standard beam delivery components. When considering other components not specifically designed as Series 48 options, please consult the factory for restrictions since excessive weight may cause damage to the laser. To prevent damage to the laser when mounting optical components, the 8–32 mounting screws must not extend further than 4.8 mm (0.1875 in) into the laser face-plate.

Diode Pointer Power Connector (optional) – provides a regulated +5 VDC, 100 mA output and is internally protected against short circuits by an auto-resetting fuse. The Diode Pointer Power connector is not installed unless the optional Diode Pointer is ordered when the laser is manufactured.

Operation

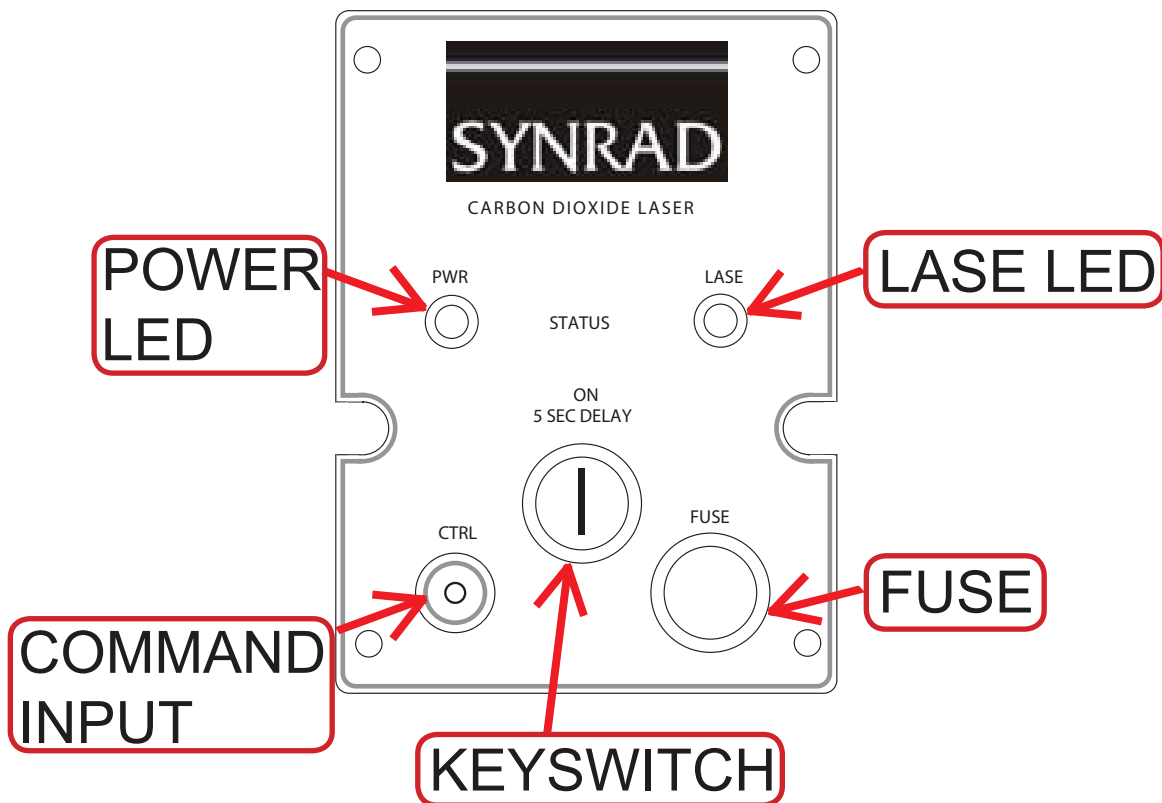

Figure 3-2 48-1/48-2 Rear panel controls and indicators.

48-1/48-2 rear panel

Power LED – illuminates green when the Keyswitch is turned to the ON position (or when an OEM laser is powered up) to indicate that power is applied to internal circuitry.

Lase LED – illuminates red to indicate the lase mode of operation. If a tickle signal is present, the LASE LED turns on after the five-second delay and becomes brighter as the PWM duty cycle is increased.

Command (CTRL) Input – accepts tickle and PWM Command signal inputs. The output of the UC-2000 Controller (or FH Series marking head) is attached to this connector.

Keyswitch (Keyswitch models only) – used to turn the laser on, off, and to reset faults. The key cannot be removed when the Keyswitch is in the ON position.

Fuse – provides overcurrent protection for the internal circuitry of the laser.

Operation

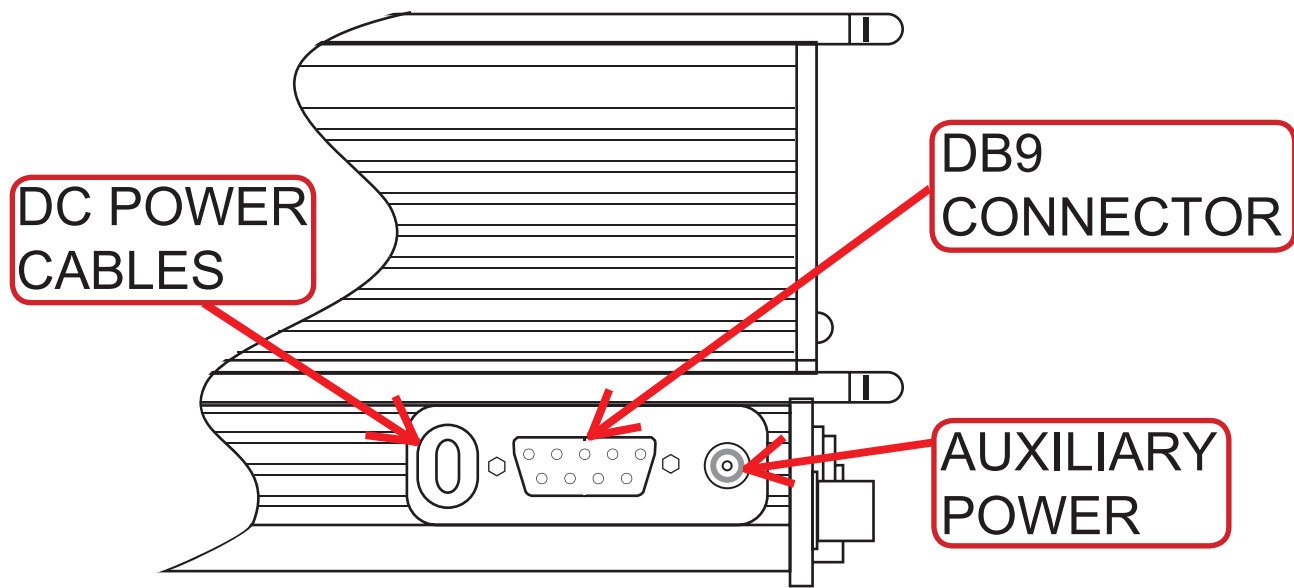

Figure 3-3 Side panel controls and indicators.

Side panel

DC Power Cables – red (+) and black (–) DC Power input cables are manufactured from #12 AWG (48-1/48-2) or #8 AWG (48-5) wire and measure 1.1 meters (3.5 feet) in length.

Auxiliary Power Connector – provides an optional 30 VDC source for powering the UC-2000 Controller. An auto-resetting solid-state fuse limits line current. Connector power is active after 30 VDC is applied to the laser.

DB-9 Connector – provides an interconnection for message, fault shutdown, remote interlock, remote keyswitch, and interface signals. Refer to the DB-9 connections section in the Technical Reference chapter for information on pin assignments and function.

Operation

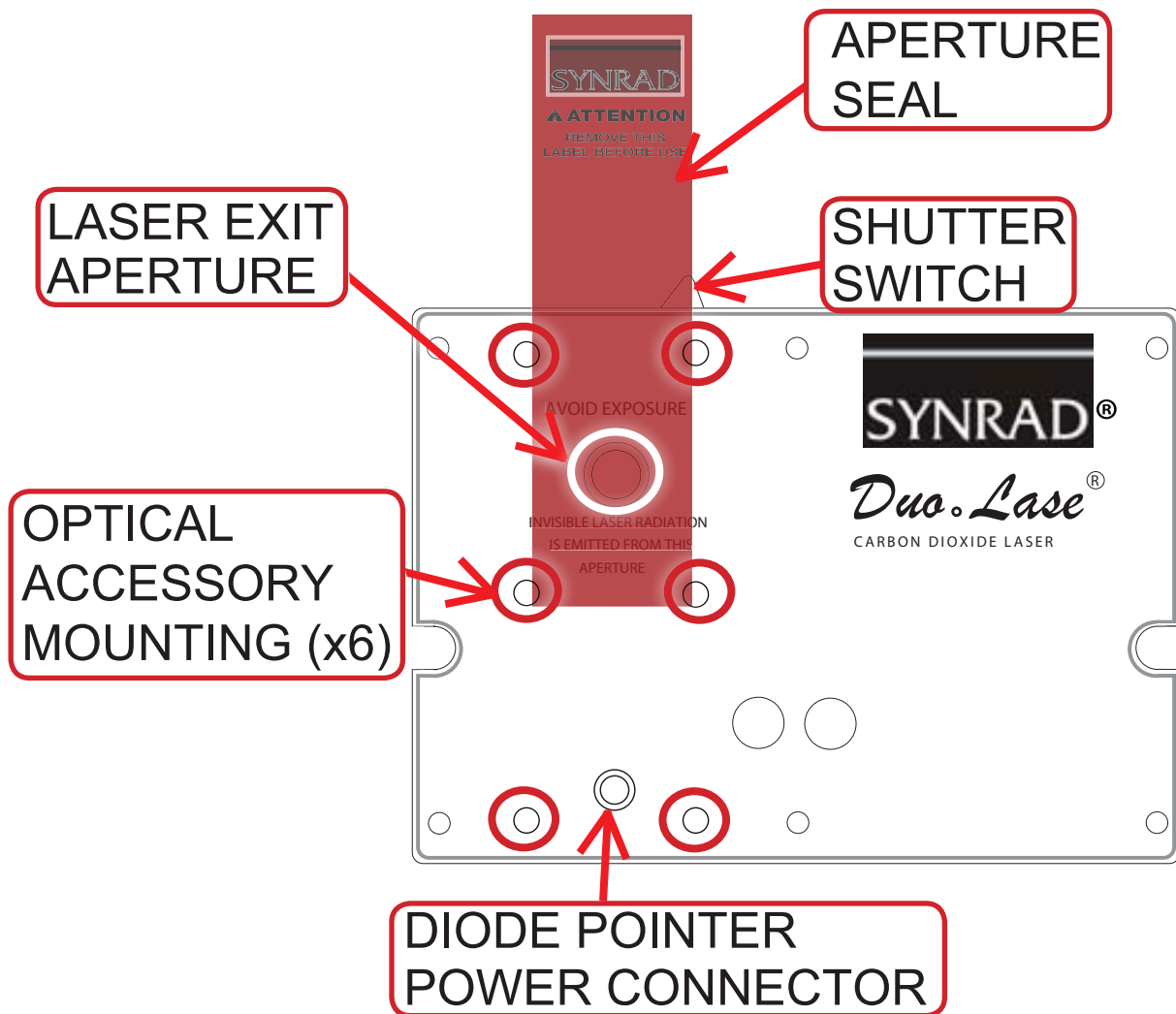

Figure 3-4 48-5 Front panel controls and indicators.

48-5 front panel

Aperture Seal – prevents dust from damaging the output coupler during shipping.

Shutter Switch (Keyswitch models only) – manually closes the aperture and interrupts power to the RF section(s).

Diode Pointer Power Connector (optional) – provides a regulated +5 VDC, 100 mA output and is internally protected against short circuits by an auto-resetting fuse. The Diode Pointer Power connector is not installed unless the optional Diode Pointer is ordered when the laser is manufactured.

Optical Accessory Mounting – provides six threaded holes for mounting standard beam delivery components. When considering other components not specifically designed as Series 48 options, please consult the factory for restrictions since excessive weight may cause damage to the laser. To prevent damage to the laser when mounting optical components, the 8–32 mounting screws must not extend further than 3/16" (4.8 mm) into the laser faceplate.

Operation

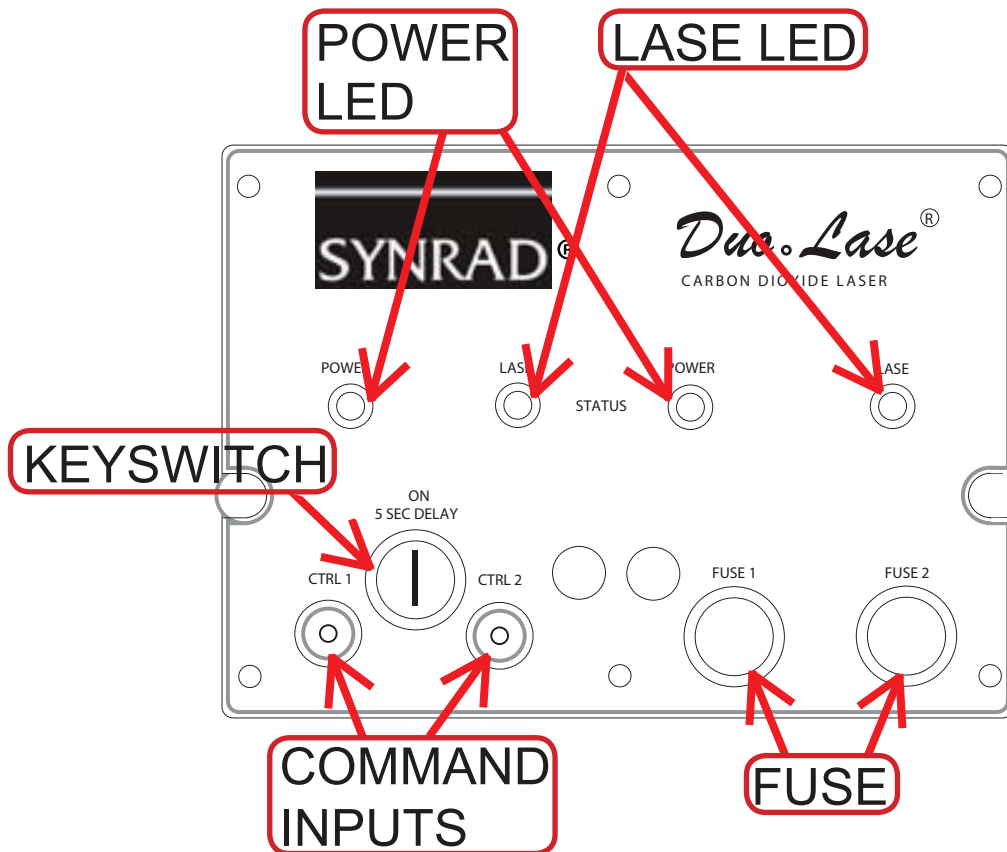

Figure 3-5 48-5 Back panel controls and indicators.

48-5 rear panel

Power LED – illuminates green when the Keyswitch is turned to the ON position (or when an OEM laser is powered up) to indicate that power is applied to internal circuitry.

Lase LED – illuminates red to indicate the lase mode of operation. If a tickle signal is present, the LASE LED turns on after the five-second delay and becomes brighter as the PWM duty cycle is increased.

Keyswitch (Keyswitch models only) – used to turn the laser on, off, and to reset faults. The key cannot be removed when the Keyswitch is in the ON position.

Command (CTRL) Input – accepts tickle and PWM Command signal inputs. The output of the UC-2000 Controller (or FH Series marking head) is attached to this connector. DC Power Cables – red (+) and black (-) DC Power input cables are manufactured from #12 AWG (48-1/48-2) or #8 AWG (48-5) wire and measure 1.1 meters (3.5 feet) in length.

DB-9 Connector – provides an interconnection for message, fault shutdown, remote interlock, remote keyswitch, and interface signals. Refer to the DB-9 connections section in the Technical Reference chapter for information on pin assignments and function.

Auxiliary Power Connector – provides an optional 30 VDC @ 350 mA source for powering the UC-2000 Controller. An auto-resetting solid-state fuse limits line current. Connector power is active after 30 VDC is applied to the laser.

4

Technical reference summary

- Technical overview – briefly describes Series 48 technology, design RF power supply and basic optical setup.
- Controlling laser power – explains various aspects of the Series 48 control signals.
- DB-9 connections – describes input/output signals and specifications for the side mounted DB-9 connector.
- DC power/DC sense cables – provides information about DC power and voltage sense cables.
- Integrating Series 48 safety features – describes how to integrate Series 48 safety features into your automated control system.
- Series 48 general specifications – provides specifications for the Series 48 laser.
- Model 48-1, 48-2, and 48-5 package outline drawing – illustrates laser package and mounting dimensions for Keyswitch and OEM 48-1 (10, 25, and 50 watt lasers respectively).
- Series 48 packaging instructions – describes how to package Series 48 lasers for shipment.

Caution **Possible** **Equipment** **Damage**



Small amounts of contaminants on the laser's output window (or on any optic in the beam path) can absorb enough energy to damage the optic. Inspect all beam delivery optics periodically for signs of contaminants and carefully clean as required.

In dirty environments, purge laser optics using filtered air or nitrogen to prevent vapor and debris from accumulating on optical surfaces.

Technical overview

- Introduction
- Plasma section
- Optical resonator
- Control circuitry
- Optical setup,
- Faults, cooling, and DuoLase®

Introduction

Series 48™ lasers incorporate the latest technology in sealed carbon dioxide devices, combining the best features of both waveguide and free space CO₂ laser technology. The all-metal laser tube construction features the ruggedness, stable optical support, and small size of waveguide lasers. Its larger bore (4.8 mm) eliminates the high optical power density of waveguide lasers with their predisposition to optical degradation and incorporates the mode purity and easy optical alignment of free space TEM₀₀ lasers. Low cost is achieved by using simple extruded and welded aluminum structures packaged together with compact, state-of-the-art RF power supplies.

48 Series lasers emit a laser beam with a wavelength of 9.3 or 10.6 microns (μm) depending on model. The beam shape is square at the laser output aperture, changing to circular at distances of approximately one meter or more from the laser. The laser beam diverges due to diffraction at a full angle of 4 mrad (milliradians), with the beam waist at the output aperture of the laser.

Power control of the laser beam is achieved by pulse width modulation (PWM) of the RF drive circuit. Modulation control can be used to gate the laser on and off at time intervals synchronized with automated processing equipment. It can also be used to control instantaneous power by adjusting the pulse width (PWM duty cycle) at a fixed modulation frequency. Both methods can be used simultaneously.

Plasma section

The laser consists of an RF-excited plasma tube with an adjustable mirror on each end, mounted together with the RF drive assembly in a single aluminum chassis. The plasma tube is made of two-inch square cross-section extruded aluminum tubing with pre-machined ends welded on. RF drive power is applied between the lower electrode and the plasma tube. The internal resonant circuit induces RF drive on the upper electrode that is 180 degrees out of phase with that of the lower electrode. Thus the voltage between the two RF electrodes is roughly twice that on either electrode, causing the plasma to form only in the 4.8 mm square bore region. The two sidewalls confine the plasma but carry negligible current. Waste heat is conducted away by all four metal sides of the bore to the outer walls of the plasma tube, where it is transferred to the chassis.

Optical resonator

The optical resonator consists of a curved total reflector and a flat Zinc Selenide (ZnSe) output coupler. The mirrors are held on with Viton (fluorocarbon) elastomeric o-rings for factory adjustment by means of three screws that are secured by adhesive after alignment. The 4.8 mm bore, in conjunction with the mirror curvature selected, limits the output beam to TEM₀₀ modes when the mirrors are properly aligned.

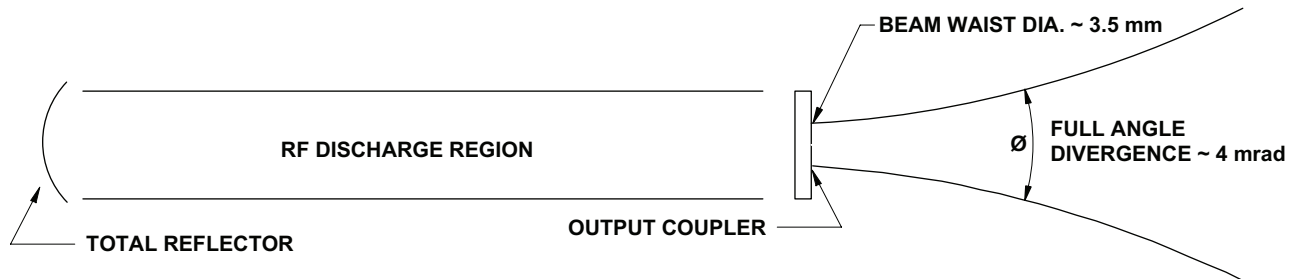

Figure 4-1 Beam characteristics.

Controlling Laser Power

Electrical description

Control of laser operation and power output levels is essentially performed using a single PCB. The Control PCB connects the modulated signal to the RF amplifier. It also provides electronics to monitor performance of RF control, output circuitry, input power, temperature, PWM accuracy, provides outputs to an externally accessible connector, and incorporates reverse polarity protection.

Functional differences between model types generally relate to the number of RF channels. Model 48-1 lasers use a single RF electrode requiring a single modulated RF drive input from the Control PCB. The 48-2 uses 2 RF electrodes and requires 2 RF channels, while the 48-5 uses 4 electrodes and 4 RF channels (2 Control PCB's). For the purpose of this description, a single channel will be described. Model specific details relating to differences in electrical characteristics are individually discussed.

The modulated input Command signal is generated externally to the laser and connected to the panel-mounted BNC connector labeled CTRL. This signal is connected to an optoisolator, the output of which is applied to the PWM switch control circuit. The PWM switch control circuit gates the PWM switch off and on at the frequency and duty cycle controlled by the modulation source. When the PWM switch closes, a potential of +30 VDC is applied to the RF Driver. The PWM control circuit provides on/off gating of the PWM switch unless disabled by the five-second delay, Shutter Switch, or the fault shutdown circuits.

Technical Reference

Technical Overview

The five-second delay disables PWM output to the RF amplifier for a period of approximately five seconds after the panel-mounted Keyswitch and Remote Keyswitch link are closed (power ON). On OEM models, the five-second delay period begins on DC power up of the laser.

The Shutter Switch allows the operator to temporarily interrupt laser output during active lase modes. A mechanical lever physically blocks the exit aperture and at the same time actuates independent micro-switches that electrically interrupt power to the RF module by disabling the PWM input optoisolator, forcing an "off" state.

Fault shutdown conditions

The output of the Keyswitch is connected to the control board through the DB-9 Connector user port. Note that the supplied DB-9 jumper plug can be removed to allow the user to insert a remotely located relay or switch in series with the Keyswitch. If the Keyswitch is left on or is electrically bypassed, the user can turn the laser on and off, and reset fault shutdowns from a remote location.

The temperature warning message output (Pin 5 of the DB-9 connector) goes low when the laser tube temperature reaches $54\text{ }^{\circ}\text{C} \pm 2\text{ }^{\circ}\text{C}$ and remains low until tube temperature falls $2\text{ }^{\circ}\text{C}$ below the trigger temperature. The warning message output does not shut down the laser. Over temperature fault shutdown occurs when laser tube temperature reaches $60\text{ }^{\circ}\text{C} \pm 2\text{ }^{\circ}\text{C}$.

Control board operation begins when the supply voltage rises above +18 VDC and remains below +36 VDC. After start-up, the control board will shut the laser down if supply voltage falls below +15 VDC or rises above +36 VDC.

If an electronics failure causes the control board to output PWM power to the RF Drivers in excess of 20% of the commanded PWM input, a fault shutdown will occur.

To reset after any fault shutdown, correct the problem(s) then cycle the Keyswitch (or Remote Keyswitch if one is present) or remove power to the laser for 30 seconds. During any fault shutdown, the fault shutdown output (Pin 1 of the DB-9 connector) will latch to low state until a keyswitched reset occurs.

The Power-On Reset feature will not allow lasing to restart after a power failure or shutdown has occurred until the Keyswitch or Remote Keyswitch is first cycled off (open circuit condition) and then back on (closed circuit). Power-On Reset is defeated on all OEM versions. OEM customers must provide this required safety feature elsewhere as part of their equipment integration.

Cooling

Coolants

SYNRAD recommends that the laser's cooling fluid contain at least 90% distilled water by volume. In closed-loop systems, use a corrosion inhibitor/algaecide such as Optishield® Plus or

Technical Reference

Technical Overview

equivalent as required. Avoid glycol-based additives because they reduce the coolant's heat capacity and high concentrations may affect power stability. For SYNRAD lasers, the minimum coolant setpoint is 18 °C (64 °F) so glycol is not necessary unless the chiller is subjected to freezing temperatures. If tap water is used, chloride levels should not exceed a concentration of 25 parts per million (PPM) and total hardness should be below 100 PPM. Install a filter on the chiller's return line and inspect frequently.

Cooling

Series 48 electronics are mounted opposite the laser tube in the smaller section of the "H" bay and share the same cooling removal as the plasma tube. Typical efficiency of CO₂ laser plasma tubes operating in a TEM₀₀ mode is 10% to 12% (radiation out to RF power in). Factor in the conversion efficiency of AC input to RF output and the overall "wall plug" efficiency of these lasers drops to about 6% to 8%, resulting in a considerable amount of heat removal, even at 10 W and 25 W output power levels; therefore, external cooling in the form of forced air- or water-cooling is required.

Since Series 48-1, 48-2 lasers are OEM products, they do not include cooling fans. Customers must provide some type of air cooling to prevent the laser from overheating. See the cooling requirements at the end of this chapter.

Note: *DO NOT* use de-ionized (DI) water as a coolant. DI water is unusually corrosive and is not recommend for mixed material cooling systems.

Setting coolant temperature

Choosing the correct coolant temperature is important to the proper operation and longevity of your laser. When coolant temperature is lower than the dew point (the temperature at which moisture condenses out of the surrounding air), condensation forms inside the laser housing leading to failure of laser electronics as well as damage to optical surfaces.

The greatest risk of condensation damage occurs when water-cooled lasers are run in a high heat/high humidity environment and the chiller's coolant temperature is colder than the dew point temperature of the surrounding air or when the system is shut down, but coolant continues to flow through the laser for extended periods of time.

The chiller's temperature setpoint must always be set above the dew point temperature. In cases where this is not possible within the specified coolant temperature range of 18 °C to 22 °C (64 °F to 72 °F), then the following steps **MUST** be taken to reduce the risk of condensation damage.

- Stop coolant flow when the laser is shut down.
- Increase coolant flow by an additional 3.8 LPM (1.0 GPM). Do not exceed a coolant pressure of 414 kPa (60 PSI).

Technical Reference

Technical Overview

Table 4.2 Dew Point Table °F temperatures.

Dew Point Table °F

Air Temp (°F)	Relative Humidity (%)															
	20%	25%	30%	35%	40%	45%	50%	55%	60%	65%	70%	75%	80%	85%	90%	95%
60 °F	-	-	-	32	36	39	41	44	46	48	50	52	54	55	57	59
65 °F	-	-	33	37	40	43	46	48	51	53	55	57	59	60	62	64
70 °F	-	33	37	41	45	48	51	53	56	58	60	62	64	65	67	69
75 °F	-	37	42	46	49	52	55	58	60	62	65	67	68	70	72	73
80 °F	35	41	46	50	54	57	60	62	65	67	69	71	73	75	77	78
85 °F	40	45	50	54	58	61	64	67	70	72	74	76	78	80	82	83
90 °F	44	50	54	59	62	66	69	72	74	77	79	81	83	85	87	88
95 °F	48	54	59	63	67	70	73	76	79	81	84	86	88	90	92	93
100 °F	52	58	63	68	71	75	78	81	84	86	88	91	93	95	97	98

Technical Reference

Technical Overview

Table 4.2 Dew point temperatures °C (Continued).

Dew Point Table °C

Air Temp (°C)	Relative Humidity (%)															
	20%	25%	30%	35%	40%	45%	50%	55%	60%	65%	70%	75%	80%	85%	90%	95%
16 °C	-	-	-	0	2	4	5	7	8	9	10	11	12	13	14	15
18 °C	-	-	1	3	4	6	8	9	11	12	13	14	15	16	17	18
21 °C	-	1	3	5	7	9	11	12	13	14	16	17	18	18	19	21
24 °C	-	3	6	8	9	11	13	14	16	17	18	19	20	21	22	23
27 °C	2	5	8	10	12	14	16	17	18	19	21	22	23	24	25	26
29 °C	4	7	10	12	14	16	18	19	21	22	23	24	26	27	28	28
32 °C	7	10	12	15	17	19	21	22	23	25	26	27	28	29	31	31
35 °C	9	12	15	17	19	21	23	24	26	27	29	30	31	32	33	34
38 °C	11	14	17	20	22	24	26	27	29	30	31	33	34	35	36	37

- Air-condition the room or the enclosure containing the laser.
- Install a dehumidifier to reduce the humidity of the enclosure containing the laser.

The prior table provides dew point temperatures for a range of air temperature and relative humidity values. Remember that the laser's coolant temperature must be set above the dew point temperatures shown in the chart; refer to the cooling specifications at the end of this chapter.

Duo-Lase[®] operation (48-5)

The 48-5 laser combines two laser tubes for twice the output of a standard laser. The outputs from two 25 W sealed CO₂ tubes are combined optically to provide a single diffraction-limited beam at 50 W. This optical combining technique is based on the fact that each laser is linearly polarized, allowing the use of a polarization sensitive beam combiner to achieve 98% efficiency in combining the two beams. The two components of the resulting beam are spatially parallel and collinear, reducing the normal temporal and spatial variations of a single laser. Output polarization is random and therefore superior for many cutting applications.

Important Note: ! 48-5 (50 W) lasers must be water-cooled to prevent damage to the laser. See the water-cooled connections section for more details.

The 48-5 laser uses two control boards and four RF drivers. The control boards are tied together electronically so that if a failure mode shuts down either board, both laser tubes are turned off. The control boards are equipped with individual fuses for each RF driver PWM output. In the event of an RF driver failure, only that fuse will open, allowing other RF drivers in the system to continue operating. Unless both fuses are open on a given control board, no shutdown will occur, nor is there a fault output signal.

In general, the two Command inputs (CTRL1 and CTRL2) should always be driven identically with a "Y" or "T" connector. For special applications in redundant or ultra-wide dynamic range systems, it is permissible to drive only one Command input; however, the beam's random polarization is compromised.

Optical setup

After selecting a CO₂ laser for your processing system, the two most important elements to consider are: (1) delivery optics to transmit the beam to the work area; and (2) focusing optics to focus the beam onto the part or material to be processed. Each element is crucial in the development of a reliable laser-based material processing system and each element should be approached with same careful attention to detail.

Delivery optics

Divergence, or expansion, of the laser beam is important for materials processing since a larger beam entering the focusing optic produces a smaller focused spot. Because the laser beam diverges slowly, increasing 4 mm in diameter over every meter, Series 48 lasers should be mounted a distance of 1.0–1.5 m (40–60 in) away from the work area. Right angle turning mirrors are often used in conjunction with the laser mounting position to obtain this distance. Figure below shows how right angle turning mirrors in a “flying optics” setup create this longer beam path.

Expander/collimators are optical devices that reduce beam divergence while at the same time increasing beam diameter by a selectable magnification factor. Adding an expander/collimator to the “flying optics” setup shown above would substantially reduce beam divergence and any variance in beam diameter caused by the changing optical path length. In fixed-length delivery systems where the laser is positioned only one meter away from the focusing optic and a small spot size is required, an expander/collimator is again the best solution to provide the required beam expansion before reaching the focusing optic.

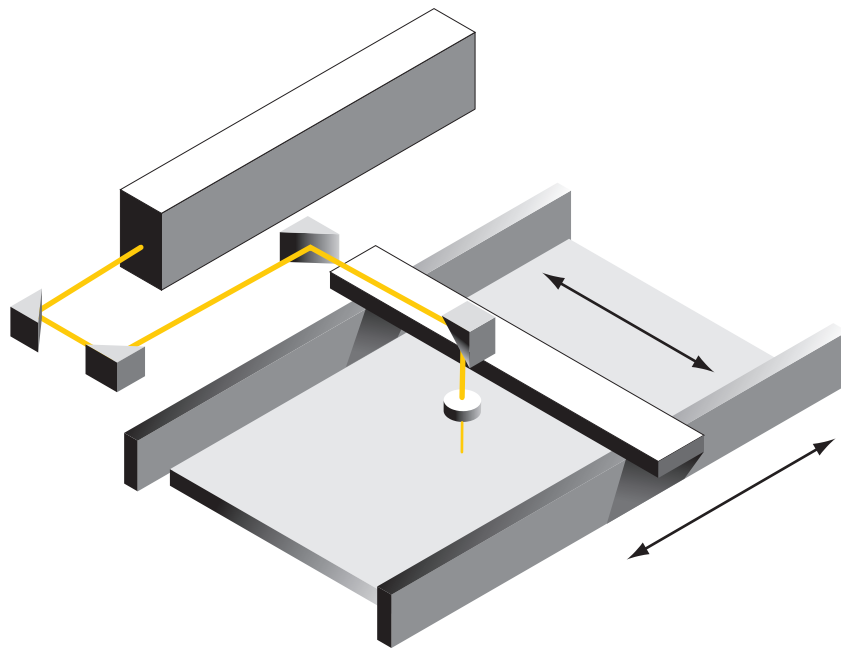

Figure 4-2 “Flying optics” beam path.

Focusing optics

When selecting a focusing optic, the primary consideration should be material thickness and any vertical tolerances that occur during final part positioning rather than making a selection based only on minimum spot size. The chosen focal length should create the smallest possible focused spot while providing the depth of field required for the material to be processed. Optics are fragile and must be handled carefully, preferably by the mounting ring only. Be careful to select optics that are thick enough to withstand the maximum assist gas pressure available for the process. This is especially important in metal cutting applications using high-pressure assist gases.

Cleanliness is another important issue affecting performance and becomes increasingly important as laser power increases. Dirty or scratched lenses will under perform, exhibit a vastly shortened lifetime, and may fail catastrophically.

When the application requires air (instead of nitrogen) as an assist gas, use only breathing quality air available in cylinders from a welding supply company. Compressed shop air contains minute particles of oil and other contaminants that will damage optical surfaces. If compressed shop air is the only choice available, it must be filtered and dried to ISO 8573-1:2010 Class 1, 2, 1 specifications shown in the table below.

Table 4-2 Assist gas purity specifications.

Assist Gas	Typical Purpose		Specification
Air	Cutting/Drilling	Breathing Grade	$\geq 99.9996\%$ purity; filtered to ISO Class 1 particulate level
Air	Cutting/Drilling	Compressed	Instrument-grade air filtered and dried to ISO 8573-1:2010 Class 1, 2, 1 (≤ 10 1.0–5.0 μm particles/ m^3 ; ≤ -40 °F dew point; ≤ 0.01 mg/ m^3 oil vapor)
Argon	Welding	High Purity Grade	$\geq 99.998\%$ purity; filtered to ISO Class 1 particulate level
Helium	Welding	High Purity Grade	$\geq 99.997\%$ purity; filtered to ISO Class 1 particulate level
Nitrogen	Cutting/Drilling	High Purity Grade	$\geq 99.9500\%$ purity; filtered to ISO Class 1 particulate level
Oxygen	Cutting/Drilling	Ultra Pure Grade	$\geq 99.9998\%$ purity; filtered to ISO Class 1 particulate level

Technical Reference

Controlling Laser Power

Control signals

- Control signals
- Operating modes

Much of the information provided in this section describes the use of a SYNRAD UC-2000 Universal Laser Controller to provide tickle and PWM Command signals to the laser. If you are using an alternate method of laser control, thoroughly review this section for an understanding of the signal requirements necessary to control SYNRAD® Series 48™ lasers. Table below lists input voltage and current specifications for 48 Series control (CTRL) inputs. Tables above and below provide specific tickle pulse and PWM Command signal parameters.

Table 4-3 Input signal specifications.

Parameter	Specification
Logic Low (Off State)	0.0 V to + 0.5 VDC; 0.0 VDC nominal
Logic High (On State)	+3.5 V to +10.0 VDC; + 5.0 VDC nominal
Maximum Current Load	6 mA (48-1 / 48-2); 12 mA (48-5)

Tickle pulse

Series 48 lasers require a 1 μ s tickle pulse delivered at a nominal 5 kHz clock frequency from the Controller. Tickle pulses pre-ionize the laser gas to just below the lasing threshold so that any further increase in pulse width adds enough energy to the plasma to cause laser emission. This tickle signal causes the laser to respond predictably and almost instantaneously to PWM Command signals, even when there is considerable delay (laser off time) between applied Command signals. The lase threshold is preset for 3 μ s \pm 0.5 μ s based on a PWM and tickle frequency input of 5 kHz. See the following table for tickle specifications.

Caution **Possible** **Equipment** **Damage**



Applying PWM Command pulses directly to the laser without first sending tickle pulses, for at least two seconds, will cause unpredictable laser emission, degrade optical rise time, and may lead to RF Driver failure.

Technical Reference

Controlling Laser Power

Table 4-4 Tickle pulse specifications.

Parameter	Specification
Tickle Frequency	5 kHz
Pulse Length	1.0 $\mu\text{s} \pm 0.2 \mu\text{s}$
Pulse Rise/Fall Time	$\leq 100 \text{ ns}$ between +0.5 V to +3.5 VDC

The UC-2000 (or FH Series marking head) does not produce tickle pulses continuously, but generates them only when the PWM Command signal is low. Tickle pulses are sent one tickle period, 200 μs , after the falling edge of a PWM Command signal pulse. Figure 3-3 illustrates tickle pulse parameters.

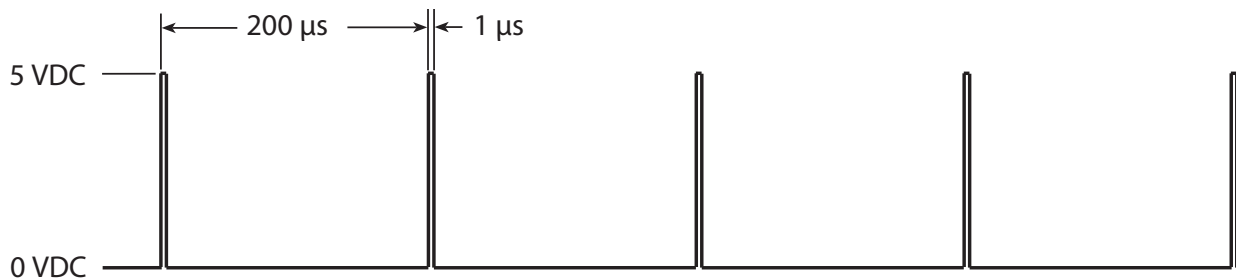

Figure 4-3 Tickle pulse waveform.

Series 48™ lasers are designed to operate at a tickle frequency of 5 kHz, which allows the laser to meet published specifications. Tickle frequencies lower than 4.5 kHz may compromise laser performance, particularly optical rise times, and stress the RF electronics thereby reducing long term reliability while tickle frequencies greater than 5 kHz may cause unintended lasing. Special care must be taken to maintain plasma ionization without lasing at tickle frequencies greater than 5 kHz. When sending 1 μs tickle pulses at 5 kHz, PWM signals can be sent at an independent, higher frequency but must go to near zero (< 1%) duty cycle to ensure laser turn-off.

Pulse width modulation (PWM)

Pulse Width Modulation, or PWM, controls laser power by varying the duty cycle of the laser's RF amplifiers, which in turn control the time-averaged RF power applied to the laser. Because laser output follows PWM input with a rise and fall time constant of $\sim 100 \mu\text{s}$, the laser cannot precisely follow Command signal frequencies over 5 kHz with duty cycles greater than 50%. Typically, the depth of modulation for a 50% duty cycle is 90 to 100% at 2 kHz and 60 to 80% at 5 kHz. Figure 3-4 shows Series 48 optical waveforms at two different modulation frequencies.

Technical Reference

Controlling Laser Power

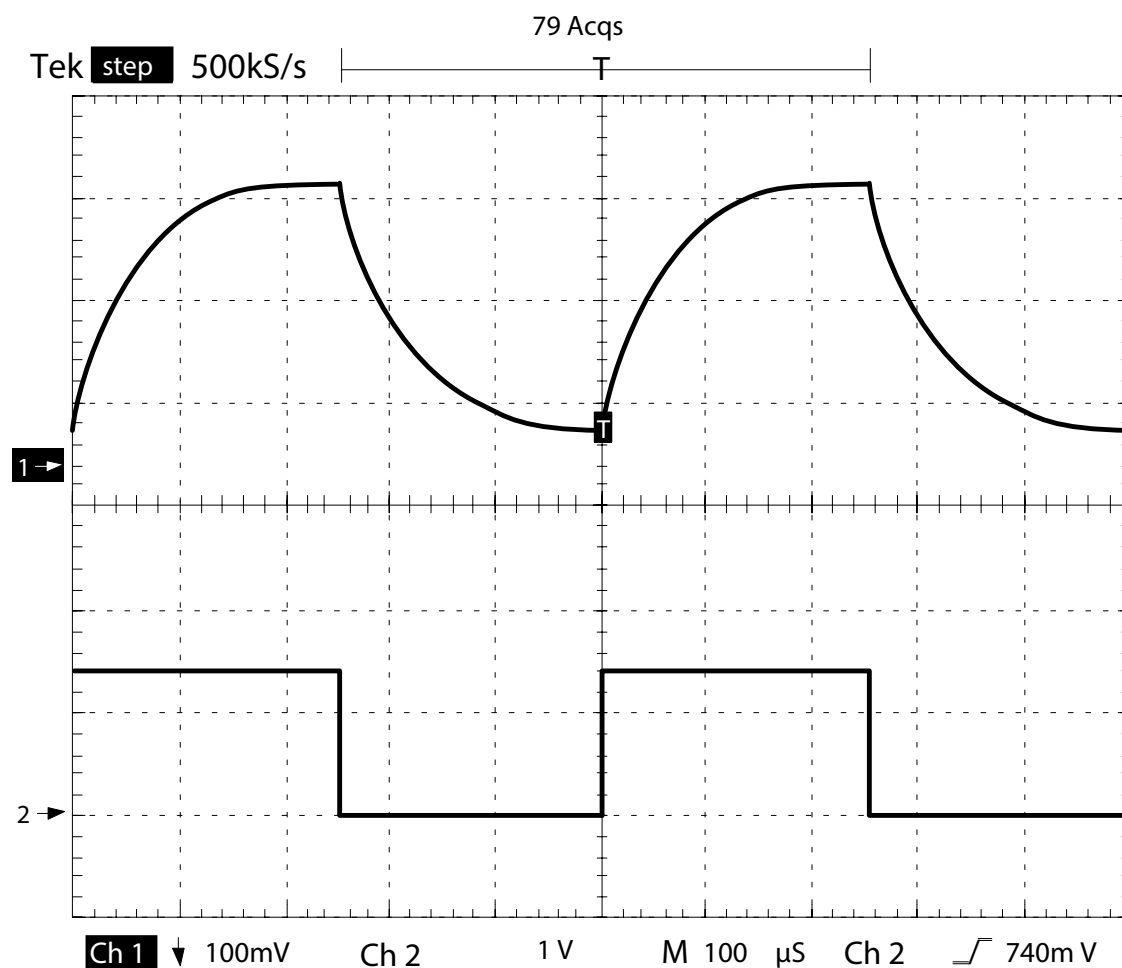

2 kHz Modulation

Figure 4-4 Series 48-2 kHz waveform. The upper waveform is laser output, the lower waveform is PWM input.

Technical Reference

Controlling Laser Power

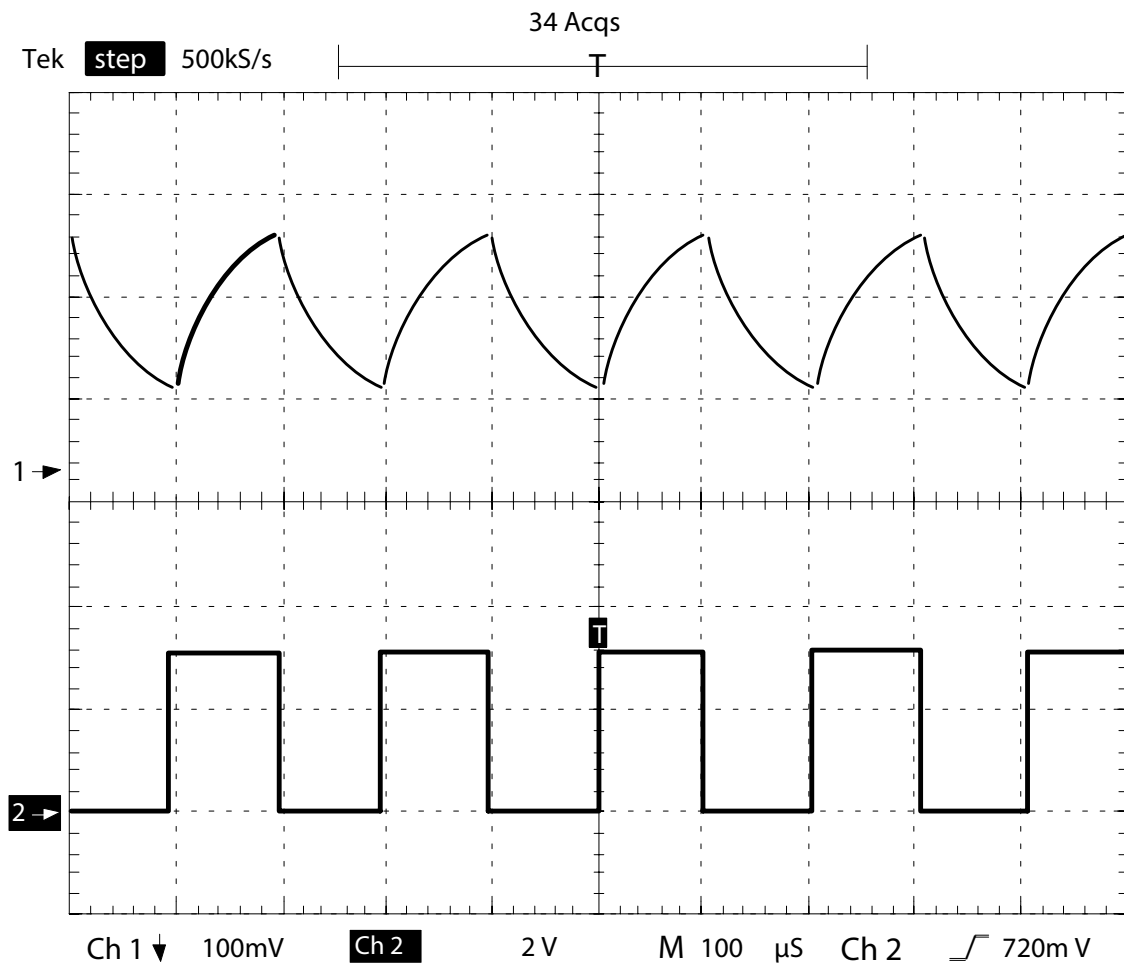

5 kHz Modulation

Figure 4-5 Series 48-5 kHz waveform. The upper waveform is laser output, the lower waveform is PWM input.

Technical Reference

Controlling Laser Power

Series 48™ lasers are designed to operate at Command signal base frequencies up to 20 kHz; however, the choice of PWM frequency depends on the user's specific application. In the majority of laser applications, the UC-2000's default Command signal frequency of 5 kHz has proven to work well. When considering Command frequencies at 5 kHz or below, please review Marking/engraving operation later in this chapter.

For high-speed motion applications that cannot tolerate any ripple in the optical beam response but still need adjustable power levels, we recommend the use of higher PWM frequencies, up to 20 kHz maximum. At 20 kHz, the laser's optical beam response no longer follows the Command input and is very nearly a DC value with just a small amount of ripple present.

Warning Always use shielded cable when connecting your PWM Command signal source to the laser's CTRL connections.

Serious personal injury In electrically-noisy environments, long lengths of unshielded wire act like an antenna and may generate enough voltage to trigger uncommanded lasing.



Command signal

The modulated Command signal applied to Series 48 lasers has three parameters: signal amplitude, base frequency, and PWM duty cycle. By changing these parameters, you can command the beam to perform a variety of marking, cutting, welding, or drilling operations.

The first Command signal parameter, signal amplitude, is either logic low—corresponding to laser beam off, or logic high—corresponding to beam on. The laser off voltage, typically 0 V, can range from 0.0 V to +0.5 VDC while the laser on voltage, typically 5 V, can range from +3.5 V to 10.0 VDC.

Base frequency, the second parameter, is the rate at which the amplitude is switched between its low and high logic states. The standard base frequency is 5 kHz, which has a period of 200 μ s. Maximum PWM frequency is 20 kHz.

The third Command signal parameter, PWM duty cycle, is the percentage of the period that the Command signal is high. If the Command signal's amplitude (at 5 kHz) is high for 100 μ s and low for 100 μ s, it has a 50% duty cycle; if the amplitude is high for 190 μ s and low for 10 μ s, it has a 95% duty cycle. The following figure illustrates Command signal parameters while the following table lists PWM Command signal specifications.

Technical Reference

Controlling Laser Power

Table 4-5 PWM Command signal specifications.

Laser State	Minimum	Nominal	Maximum
Laser Off Voltage	0.0 VDC	0.0 VDC	+0.5 VDC
Laser On Voltage	+3.5 V	+5.0 VDC	+10.0 VDC
Current (@ 5 VDC)	— —	— —	6 mA (48-1/48-2) 12 mA (48-5)
Frequency Range	0 Hz (DC)	5 kHz	20 kHz
Duty Cycle	0%	— —	100%

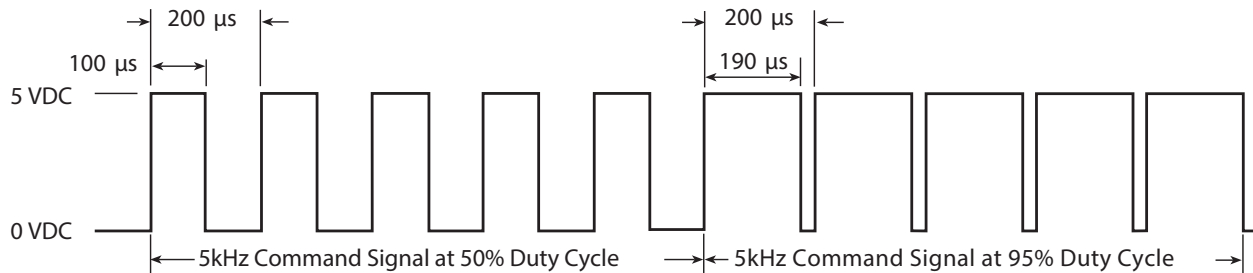

Figure 4-6 PWM Command signal waveform.

Operating modes

External control

In addition to controlling your Series 48 laser using a UC-2000 Controller, controlling the laser externally, without a UC-2000, is also possible. The two primary elements of laser control are gating, the ability to turn the laser on and off at the appropriate times, and power, the ability to control the laser's output energy. Both gating and power can be handled by a device such as a personal computer, Programmable Logic Controller (PLC), or a function generator capable of sending PWM pulses at the proper time (gating) and with the proper duty cycle (power).

Analog voltage or analog current control

Although Series 48™ lasers cannot be controlled directly by analog voltage or current signals, this type of control is possible when using the UC-2000 Controller. The Controller is connected normally to the laser and analog voltage or current signals sent to the UC-2000's ANV/C connector then control both gating and power.

Technical Reference

Controlling Laser Power

To generate the correct analog voltage from a computer or PLC, a Digital-to-Analog (D/A or DAC) card capable of generating 0 V (laser off) to 10 V (maximum laser power) must be installed. To generate the proper analog current, install a D/A card that can generate 4 mA (laser off) to 20 mA (maximum power). Software able to control your analog output card is required for both configurations.

UC-2000 Universal Laser Controller

SYNRAD recommends using a UC-2000 Universal Laser Controller to generate tickle pulses and Pulse Width Modulated (PWM) Command signals to control the laser's output power. The UC-2000 requires 15–50 VDC @ 35 mA, supplied from either its wall plug transformer or from the Auxiliary Power connector on the side of Series 48 lasers. Refer to the UC-2000 Laser Controller Operator's Manual for information about UC-2000 operation.

To connect a UC-2000 Controller (available separately from SYNRAD), perform the following steps:

- 1 Remove DC power from the laser. Fabricate a suitable DB-9 plug so Pin 1, PWM Positive, connects to the center pin of the Power/Control cable's BNC connector and Pin 6, PWM Negative, connects to the shield.
- 2 If your system does not provide an enable input to the DB-9 plug, then jumper Pin 9, Laser Enable, to Pin 5, DC Out.
- 3 Connect the DB-9 plug to the DB-9 I/O connector on the rear of the laser.
- 4 Connect the miniature DC power plug on the UC-2000's Power/Control cable to the miniature connector on the wall plug transformer cable.
- 5 Connect the mini-DIN connector on the other end of the UC-2000's Power/Control cable to the Laser connector on the UC-2000's rear panel.

Technical Reference

Controlling Laser Power

Continuous wave (CW) operation

In some applications, such as high speed marking or cutting, the time constant of the laser and the PWM modulation causes a series of dots that may be visible on the marking surface instead of a “clean” line. Operating the laser in CW mode will prevent this behavior from occurring. To operate the laser in CW mode, a constant +5 VDC signal is applied to the CTRL input(s) of the laser. This constant voltage source forces the internal switching electronics to remain on, providing continuous and uninterrupted laser output power.

For pure CW operation, a steady +5 V signal can be applied through this connector (a tickle signal must be applied during laser-off periods). This input is optically-isolated from the chassis and power supply ground circuit, but must not be subjected to common mode voltages greater than ± 50 VDC from chassis ground. The 48-5 laser has two Command inputs, CTRL1 and CTRL2, that should always be driven identically from the signal source by using a “Y” cable or “T” BNC connector.

Gated operation

In many marking and cutting applications, the laser is required to pulse, or gate, on and off in synchronization with an external control signal (typically from a computer or function generator operating in the range from DC to 1 kHz). To pulse or gate the laser, connect a signal providing +5.0 VDC pulses to the Gate connector on the rear panel of the UC-2000.

Users who intend to use a gating signal should set the UC-2000’s gate input logic to internal Pull-Down (normally off) mode. This prevents the beam from being enabled unless a high level (+3.5 V to +5.0 VDC) signal is applied to the Gate input connector. In the pull-down (normally off) mode an asserted logic low state, short circuit to ground, or an open or disconnected Gate input locks the beam off.

Warning **Serious** **personal** **injury**



The UC-2000’s default gate logic is factory set to internal Pull-Up (normally on) mode so that an open (disconnected) Gate input causes the laser to turn on. This functionality allows the user to easily test and verify laser operation prior to integration.

In an integrated system, you should configure the UC-2000’s gate input logic to internal Pull-Down (normally off) mode. This prevents the beam from being enabled unless a high level (+3.5 V to +5.0 VDC) signal is applied to the Gate input connector. In the Pull-Down (normally off) mode, an asserted logic low signal, short circuit to ground, or an open or disconnected Gate input locks the beam off.

Note: When operating in CW mode, laser power output cannot be adjusted. If you require an adjustable output power level, refer to the Pulse width modulation (PWM) section for information regarding high frequency operation.

Technical Reference

Controlling Laser Power

Many CO₂ lasers operating in applications requiring short gating pulses at repetition rates below 500 Hz will exhibit some leading edge overshoot regardless of the PWM frequency. This occurs because a cooler lasing medium (the CO₂ gas) is more efficient than a hotter one. This overshoot is more pronounced at lower gating frequencies since the gas has a longer time to cool down between Command signal pulses.

Caution **Possible** **Equipment** **Damage**



Do not ground Remote Keyswitch or Remote Interlock inputs to an external circuit—this will damage laser circuitry. Any external circuit(s) connected to these terminals must be floating with respect to ground. We recommend using “dry circuit” (zero voltage) switches or relay circuitry.

Do not apply a voltage to the Remote Interlock Input on DB-9 Connector Pin 3 as this will damage internal laser circuitry. The Remote Interlock Input on Pin 3 is a “dry-circuit” (zero voltage) input and must connect only to Pin 2 or Pin 4 to complete the interlock circuit.

Marking/engraving operation

When the delay between the end of one PWM Command signal pulse and the beginning of the next PWM pulse exceeds 200 microseconds (less than or equal to 5 kHz), the on-board tickle generator sends a tickle pulse to maintain plasma ionization in the tube. Because the on-board tickle generator can not anticipate when the next PWM Command pulse will arrive; the tickle pulse (which typically lasts for 2–6 μ s depending on the laser) can effectively merge with a PWM signal that follows closely afterwards. When the PWM pulse that follows is short, causing the tickle pulse to become a significant fraction of the PWM pulse duration, then the tickle pulse effectively substantially increases the length of the PWM pulse it has merged with. For subtle marking applications on sensitive, low threshold materials this lengthened PWM pulse may affect mark quality.

While this situation can occur when using PWM Command signal frequencies of 5 kHz and less, it is important to note that it isn't the Command signal frequency itself that is the determining factor but rather this behavior happens only when the off time between PWM pulses exceeds 200 microseconds.

Technical Reference

DB-9 I/O Connections

DB-9 connections

Series 48™ lasers are equipped with a female DB-9 connector mounted to the sidewall of the laser. The DB-9 Connector provides the user with a convenient method for monitoring fault conditions (over temperature, control/RF circuitry failure, etc.) and adds remote interlock, remote keyswitch (relay or switch), message output, and remote LED indicator capability. These signals allow you to connect remote keyswitch, LASE, and ready (PWR) indicators to a remote operator's station or connect a remote interlock safety switch to interlock equipment doors or panels.

A factory-installed jumper plug is attached to the DB-9 Connector on each laser to enable normal operation on initial start-up. Two jumpers are wired into the plug as shown in the figure below. The jumper between Pin 6 and Pin 7 closes the Remote Keyswitch Input and the jumper between Pin 3 and Pin 4 closes the Remote Interlock Input. If the jumper plug is removed, then you must connect the appropriate external remote interlock or remote keyswitch circuitry in order to enable lasing. To take advantage of the DB-9 functions described in the following table, 'DB-9 pin assignments', you must manufacture a connecting cable that properly integrates the DB-9 signals into your automated system. A spare DB-9 male connector and cover is included with each laser (Keyswitch only) to facilitate cable manufacture.

For OEM lasers, a plug is installed in place of the Keyswitch and the remote keyswitch pins of the DB-9 Connector then become the external power on/off/reset control means.

Note: On lasers manufactured as OEM (-S) version lasers, i.e. without a Key switch, the Remote Interlock function is bypassed internally; however, the Remote Keyswitch function on Pin 6 and Pin 7 provides a similar functionality.

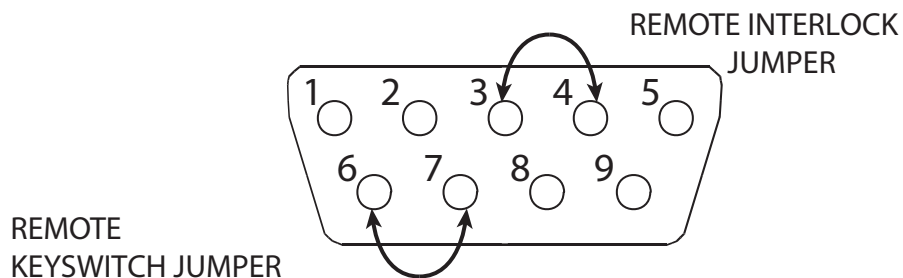

Figure 4-7 Factory-installed DB-9 jumper plug wiring.

Technical Reference

DB-9 I/O Connections

Note: You can control Series 48™ lasers from an alternate user-supplied PWM Command signal source. See Controlling laser power in the Technical Reference chapter for control signal descriptions.

Series 48 lasers are equipped with a female DB-9 connector mounted to the sidewall of the laser that provides a means of monitoring fault conditions (over-temperature, control/RF circuitry failure) and adds remote interlock, remote keyswitch (relay or switch), message output, and remote LED indicator capability. For a complete description of DB-9 pin assignments and functions, see the DB-9 connections section in the Technical Reference chapter.

A factory-installed jumper plug is attached to the DB-9 Connector to enable normal laser operation (see Figure 3-6). If the jumper plug is removed, you must (1) jumper Pin 3 to Pin 4 (or Pin 2) or connect to external “remote interlock” circuitry and (2) you must jumper Pin 6 to Pin 7 or connect to external “remote keyswitch” circuitry as described in the DB-9 connections section in the Technical Reference chapter.

Note: On lasers manufactured as OEM (-S) version lasers, i.e. without a Keyswitch, the Remote Interlock function is bypassed internally; however, the Remote Keyswitch function on Pin 6 and Pin 7 provides a similar functionality.

- 1 Connect the mini-DIN connector on the end of the UC-2000 Controller’s Power/Control cable to the Laser connector on the rear panel of the UC-2000.
- 2 Connect the miniature DC power plug on the UC-2000’s Power/Control cable to the laser’s side-mounted Auxiliary Power connector.

To use the UC-2000’s wall plug transformer instead, connect the miniature DC power plug on the UC-2000’s Power/Control cable to the miniature connector on the wall plug transformer cable

- 3 On 48-1 and 48-2 lasers, attach the BNC connector on the end of the UC-2000’s Power/Control cable to the BNC connector labeled CTRL on the rear of the laser.

On 48-5 lasers, attach the long “leg” of the BNC “Y” control cable to the BNC connector on the UC-2000’s Power/Control cable. Attach the short “legs” of the “Y” cable to the laser’s CTRL1 and CTRL2 connectors located on the rear of the laser.
- 4 If your application uses external gating signals to command On/Off switching of the laser, attach a BNC cable between your gate signal source and the UC-2000’s Gate connector.
- 5 If your application uses external analog voltage or current signals to control the PWM duty cycle of the laser, attach a BNC cable between your analog voltage or current source and the UC-2000’s ANV/ANC connector.

User I/O connections

- User I/O connection summary
- Input/output signals
- Sample I/O circuits

The PWM Command signal and all input/output (I/O) control signals are connected to the User I/O port. Please refer to the figure below for the 15 pin female D-type sub-miniature connector on the rear panel. The figure below illustrates the pin arrangement of the User I/O connector.

Table 4-6 DB-9 pin assignments.

Pin #	Function & Description
-------	------------------------

- | | |
|---|---|
| 1 | Fault Shutdown Output
Indicates failure of internal circuitry or existence of over temperature ($> 60\text{ }^{\circ}\text{C} \pm 2\text{ }^{\circ}\text{C}$), over voltage, or under voltage fault. This active low signal (referenced to Pin 2 or Pin 4) transitions from +15 V (normal operation) to 0 VDC when a fault occurs. Use this output signal to disable external processes during a fault ¹ . See the two following table(s) for output signal specifications. |
| 2 | Signal Ground
Signal ground/chassis ground for Pins 1, 3, 5, 8, and 9. |
| 3 | Remote Interlock Input
Disables the laser when an interlock switch wired to this input from an equipment door or panel is opened. Ground this input to Pin 2 or Pin 4 only. Do not apply a voltage to this pin ² . See the two following table(s) for input signal specifications. As shipped, Pins 3 and 4 are connected by the factory-installed jumper plug to enable the Remote Interlock function. |
| 4 | Signal Ground
Signal ground/chassis ground for Pins 1, 3, 5, 8, and 9. |
| 5 | Message Output
This active low signal (referenced to Pin 2 or Pin 4) transitions from +15 V (normal operation) to 0 VDC when a pre-shutdown temperature warning occurs (when laser temperature reaches $54\text{ }^{\circ}\text{C} \pm 2\text{ }^{\circ}\text{C}$) and remains low until temperature falls $2\text{ }^{\circ}\text{C}$. Use this output to notify user of need to increase laser cooling or risk shutdown ¹ . See the two following table(s) for output signal specifications. |
| 6 | Remote Keyswitch Input
Connect a remote relay or switch in series with the laser Keyswitch to control laser On / Off / Reset functions. Connect Pin 6 to Pin 7 to run; open this connection to halt lasing or reset faults. As shipped, Pins 6 and 7 are connected by the factory-installed jumper plug to enable the Remote Keyswitch function ^{2,3} . See the two following table(s) for input signal specifications. |

Technical Reference

User I/O Connections

Pin # Function & Description

- 7** Remote Keyswitch Output
Connect Pin 7 to Pin 6 to enable the Remote Keyswitch function (see Pin 6 description above). Pin 7 is at DC line potential (+30 VDC) only when the Keyswitch is set to ON. As shipped, Pins 6 and 7 are connected by the factory-installed jumper plug^{3,4}. See the two following table(s) for output signal specifications.
- 8** Remote Lase LED Output
Connect an LED or LED-optoisolator between Pin 8 and Signal Ground for a remote LASE indication^{5,6}. See the two following table(s) for output signal specifications.
- 9** Remote Ready LED Output
Connect an LED or LED-optoisolator between Pin 9 and Signal Ground for a remote Ready (PWR) indication⁵. See the two following table(s) for output signal specifications.
-

- 1** Pin 1 and Pin 5 are active low outputs. Specifications: OFF: +15 VDC, 5 mA into 3 kOhm. ON: < 1 VDC, sinking 100 mA.
- 2** "Dry-circuit" (zero voltage) external switches are required since current into remote interlock and debounced remote keyswitch pins is negligible.
- 3** Connecting an LED to Pins 6 or 7 to indicate keyswitch status requires an external current-limiting resistor.
- 4** The remote keyswitch output pin is not current-limited or fused.
- 5** Pins 8 and 9 can be directly connected to the anodes of LEDs or LED-input optoisolators without external current limiting devices. Connect LED cathodes to Pin 2 or 4. Current is limited internally to 20 mA at 3.3 V maximum.
- 6** The output of Pin 8, the Remote Lase LED Output, is a Pulse Width Modulated (PWM) signal based on the PWM Command input signal. It is not a steady state (on/off) output.

Technical Reference

User I/O Connections

DB-9 connections

The figure below shows the physical layout and pin identification of the Series 48™ DB-9 Connector. Refer to the following tables in the next section describing input/output signal specifications.

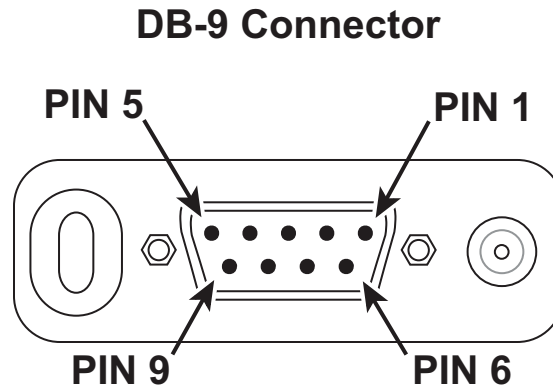

Figure 4-8 Physical layout of Series 48 DB-9 Connector.

Table 4-7 DB-9 Connector input signal specifications.

Pin #	Input Signal Name	Input Specifications
3	Remote Interlock Input	50 mA maximum @ 30 VDC. Important Note: Use “dry
6	Remote Keyswitch Input	circuit” (zero-voltage) external switches to prevent internal circuit damage.

Table 4-8 DB-9 Connector output signal specifications.

Pin #	Output Signal Name	Output Specifications
1	Fault Shutdown Output	Active Low output signal: Off: + 15 VDC, 5 mA into 3 kOhm;
5	Message Output	On: < 1 VDC, sinking 100 mA.
7	Remote Keyswitch Output	50 mA maximum @ 30 VDC. Output active (+30 VDC) when Keyswitch ON or bypassed (OEM models).
8	Remote Lase LED Output	Current-limited to 11 mA @ 2.4 VDC maximum. Voltage output is pulse width modulated at input PWM Command signal frequency, <u>not</u> a steady state on/off signal.
9	Remote Ready LED Output	Current-limited to 11 mA @ 2.4 VDC maximum.

Technical Reference

User I/O Connections

Sample DB-9 Connector I/O circuits

Sample input circuits

The figure below illustrates a method of connecting a relay contact or limit switch to act as a remote keyswitch. Remember that Remote Keyswitch and Remote Interlock inputs are “dry circuit” or zero-voltage inputs.

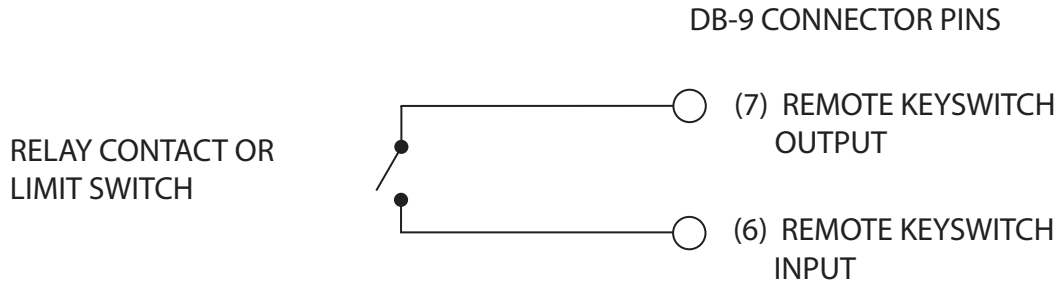

Figure 4-9 Remote Keyswitch circuit.

The figure below shows how to connect the laser's Remote Interlock input in series with one or more door safety switches or relay contacts.

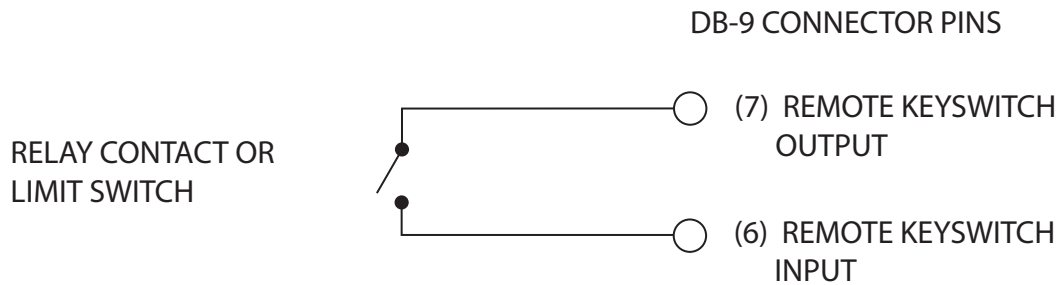

Figure 4-10 Remote Interlock circuit.

Technical Reference

User I/O Connections

Sample output circuits

Figures below illustrate how to connect the laser's Remote Ready LED Output to a Programmable Logic Controller (PLC) DC input module using current sourcing, current sinking, and resistive pull-up methods.

Note: You can use these same circuits to monitor the laser's Remote Lase LED Output (DB-9, Pin 8); however, the Remote Lase LED Output is not a steady state (on/off) output. It is a Pulse Width Modulated (PWM) signal based on the PWM Command input signal to the laser.

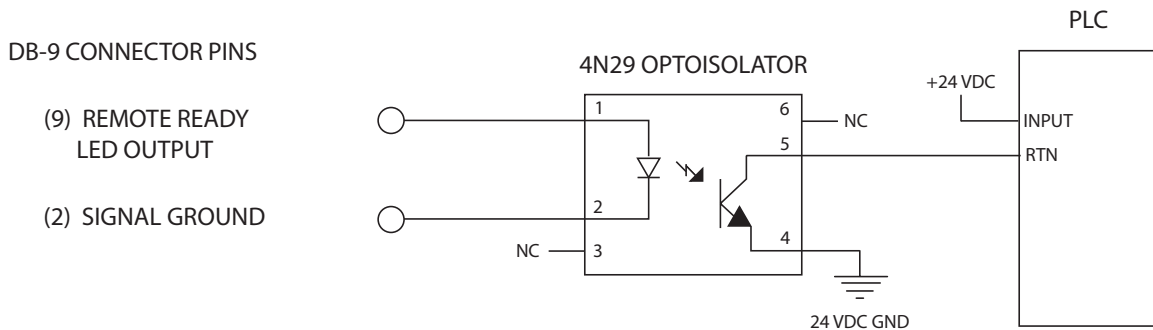

Figure 4-11 Remote Ready output to PLC input (PLC sourcing).

The following figure shows how to connect the Message Output signal on the DB-9 Connector to a PLC. The Message Output function provides a pre-shutdown temperature indication when laser tube temperature reaches $54\text{ }^{\circ}\text{C} \pm 2\text{ }^{\circ}\text{C}$, signaling the need to increase laser cooling or risk laser shutdown if laser temperature rises to $> 60\text{ }^{\circ}\text{C} \pm 2\text{ }^{\circ}\text{C}$.

Technical Reference

User I/O Connections

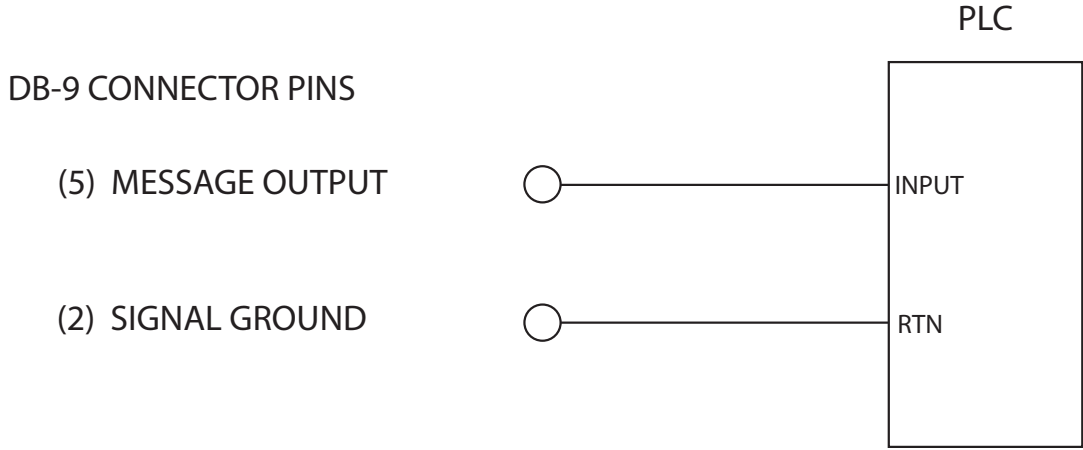

Figure 4-12 Message Output to PLC input.

The following figure illustrates how to connect the Fault Shutdown Output signal to a PLC. The Fault Shutdown Output function signals a laser shutdown due to an under/over voltage condition, an over temperature condition, or failure of internal circuitry.

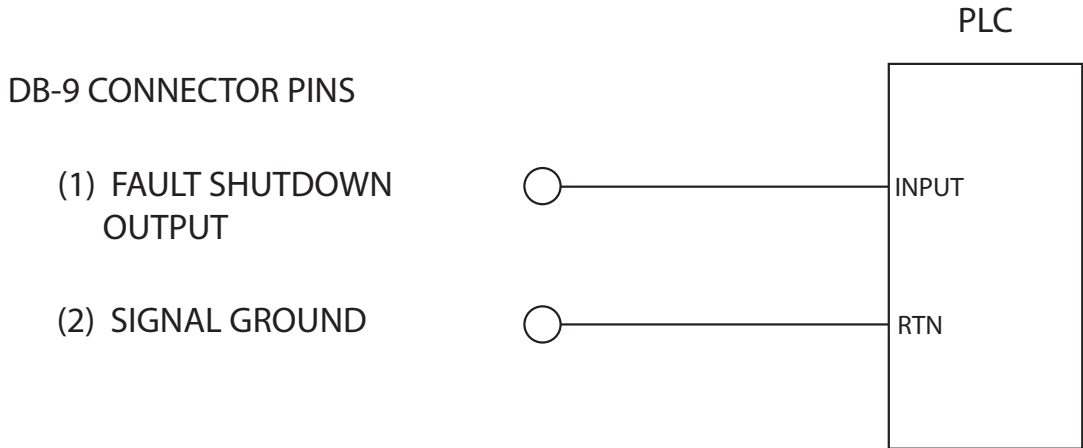

Figure 4-13 Fault Shutdown Output to PLC input.

Technical Reference

Integrating Safety Features

Integrating Series 48™ safety features

The Integrating Series 48 safety features section includes subsections:

- Remote Keyswitch functions
- Remote interlock functions

The Series 48 DB-9 Connector allows system integrators or end-users to integrate Series 48 laser safety features into their control system. In particular, the Series 48 Remote Keyswitch and Remote Interlock functions serve to disable DC power to the laser's RF driver. Without power, the RF driver cannot supply PWM Command or tickle signals to the resonator, causing the CO₂ gas to remain in a zero-energy state.

Remote keyswitch functions

Keyswitch lasers

After DC power-up, or after a fault or open interlock condition, the Keyswitch must be toggled to reset the laser, which enables the PWR LED and signals that DC power is applied to the RF driver. Over temperature faults are reset by removing, then reapplying DC power after the laser has cooled.

For Keyswitch lasers in automated control systems, this reset function is provided by the Remote Key-switch signal via pins 6 and 7 on the DB-9 Connector. To use this "remote keyswitch" functionality, first place the Keyswitch in the ON position. To reset a fault condition, open and then close a "dry-circuit" (zero voltage) switch or relay contact between Pin 6, Remote Key-switch Input, and Pin 7, Remote Keyswitch Output. Reconnecting Pin 6 to Pin 7 applies power to the RF driver and begins a five-second delay after which lasing is enabled. The RF driver is disabled when the remote keyswitch circuit is open.

Your control system can monitor the laser's power-on status through the DB-9 Connector by connecting your system's input between Pin 9, Remote Ready LED Output, and Pin 2 or Pin 4, Signal Ground. The Remote Ready LED Output goes active when the laser is enabled (PWR LED turns On), indicating that lasing is possible after the five-second delay. The output is inactive (PWR LED off) when lasing is disabled. Refer back to Table 3-6, DB-9 pin assignments for specific details.

Important Note:

 Pin 9, the Remote Ready LED Output, is a current- and voltage-limited output meant only for direct connection to an LED or LED-input optoisolator.

Technical Reference

Integrating Safety Features

OEM Lasers

On OEM lasers, the PWR LED illuminates on DC power-up and five seconds later DC power is applied to the RF driver. To reset a fault condition, remove DC power for 30 seconds and then reapply power to the laser or toggle (open, then close) the Remote Keyswitch signal via pins 6 and 7 on the DB-9 Connector. To use this “remote reset” functionality, open and then close a “dry-circuit” (zero voltage) switch or relay contact between Pin 6, Remote Keyswitch Input, and Pin 7, Remote Keyswitch Output. Reconnecting Pin 6 to Pin 7 applies power to the RF driver and begins a five-second delay after which lasing is enabled.

Your control system can monitor the laser’s power-on status through the DB-9 Connector by connecting your system’s input between Pin 9, Remote Ready LED Output, and Pin 2 or Pin 4, Signal Ground. The Remote Ready LED Output goes active when the laser is enabled (PWR LED turns On), indicating that lasing is possible after the five-second delay. The output is inactive (PWR LED off) when lasing is disabled. Refer back to Table 3-6, DB-9 pin assignments for specific details.

Remote interlock functions

Keyswitch Lasers

Interlock circuits are often used to disable machinery when a shield, panel, or door is opened. The Series 48™ remote interlock connects directly into an external, zero-voltage remote interlock circuit to prevent lasing by removing DC power from the laser’s RF driver boards when the circuit is electrically “open”.

Remote interlock functionality is provided by the Remote Interlock Connection via Pin 3 on the DB-9 Connector. Lasing is enabled when the Remote Interlock Connection signal is closed and disabled when the Remote Interlock Connection signal is electrically “open”. DC power is applied to the RF driver only when the Remote Interlock Connection signal is closed (PWR LED is illuminated). When the Remote Interlock Connection is opened and then closed, you must toggle the Keyswitch or Remote Keyswitch Input to reset the laser.

To use the Series 48 remote interlock feature, connect Pin 3, Remote Interlock Connection, to your “dry-circuit” (zero-voltage) interlock circuit and then ground the circuit to Pin 2 or Pin 4, Signal Ground.

Caution **Possible** **Equipment** **Damage**



Do not apply a voltage to Pin 3, Remote Interlock Connection on the DB-9 Connector—the laser will be damaged. This input is a “dry-circuit” (zero voltage) input and must be grounded to either Pin 2 or Pin 4 to complete the interlock circuit.

Technical Reference

Integrating Safety Features

Lasing is enabled when Pin 3 is grounded (when the external interlock circuit is closed). If the external interlock circuit opens, then Pin 3 opens and lasing is disabled. To enable lasing again, you must close the interlock circuit and toggle the Keyswitch or Remote Keyswitch Input. This resets the laser and begins a five-second delay after which lasing is enabled.

Your control system can monitor the laser's power-on status through the DB-9 Connector by connecting your system's input between Pin 9, Remote Ready LED Output, and Pin 2 or Pin 4, Signal Ground. The Remote Ready LED Output goes active when the laser is enabled (PWR LED turns On), indicating that lasing is possible after the five-second delay. The output is inactive (PWR LED off) when lasing is disabled. Refer back to Table 3-6, DB-9 pin assignments for specific details.

Technical Reference

Cooling Fittings

Caution

Possible Equipment Damage



Read **guidelines for cutting and installing** tubing before installation.

Assure you understand the guidelines before proceeding to the next step.

Make sure to **connect the cooling system exactly as described** for your particular laser.

Water-cooled connections

Setting coolant temperature

Choosing the correct coolant temperature is important to the proper operation and longevity of your laser. When coolant temperature is lower than the dew point (the temperature at which moisture condenses out of the surrounding air), condensation forms inside the laser housing leading to failure of laser electronics as well as damage to optical surfaces.

The greatest risk of condensation damage occurs when the laser is in a high heat/high humidity environment and the chiller's coolant temperature is colder than the dew point of the surrounding air or when the system is shut down, but coolant continues to flow through the laser for extended periods of time. Refer to the dewpoint table in the Maintenance and Troubleshooting chapter within this manual.

- Air-condition the room or the enclosure containing the laser.
- Install a dehumidifier to reduce the humidity of the enclosure containing the laser.
- Stop coolant flow when the laser is shut down.
- See the coolant pressure specifications within this chapter.

Note: Refer to the Series 48 Water Cooled Quick Start Guide and the drawings within this chapter. Also see the cooling specifications within this chapter.

Technical Reference

Cooling Fittings

Water-cooled connections

Coolant fitting guidelines

- Cut tubing lengths generously to allow for trimming.
- Cut tubing squarely; diagonal cuts may not seal properly. Trim away any burrs if the cut is “ragged”.
- Avoid excessive stress on fittings by creating a gentle radius when bends in the tubing are close to fittings. Bending tubing too sharply will compromise the sealing properties of the fitting.
- Never allow the tubing to kink, since kinking severely restricts coolant flow.
- Push tubing completely into the fitting, then pull the tubing to verify that it is locked into place.
- If tubing must be disconnected from a fitting, first push and hold the tubing slightly into the fitting. Next push the white fitting ring evenly towards the fitting, and then pull the tubing free.
- After disconnecting tubing from a fitting, trim 12.7 mm (0.5 in) from its end before reconnecting. Trimming the end of the tubing before reconnecting provides an undisturbed sealing surface.
- You must provide fittings that will adapt the laser’s 1/4” or 3/8” O.D. polyethylene cooling tubing to your chiller’s Inlet and Outlet ports. These fittings can be either “quick disconnect” or compression type fittings.

Note: Because Series 48 cooling tubing is specified in inch sizes, the use of metric tube fittings is discouraged unless you have installed the appropriate inch-to-metric tubing adaptors. The use of metric fittings on inch size tubing will lead to coolant leaks and/or pressurized tubing blowing-off the fitting(s).

If your integrated laser application uses metric cooling tubing, we recommend the installation of tubing adaptors to convert 48-1/48-2 cooling kit fittings from 1/4” tubing to 6 mm metric tubing. For 48-5 cooling kits, convert the 3/8” tubing to 8 mm metric tubing. These tubing adaptors are available from many tubing and fitting manufacturers.

Technical Reference

Cooling Fittings

48-1/48-2 and 48-5 cooling tubing connections

If water cooling is desired with the 48-1/48-2, see the appropriate Series 48 Quick Start Guide located on our website. Also reference the drawings at the end of this chapter as necessary.

Technical Reference

Series 48 General Specifications

Model 48-1 general specifications

Table 4-9 Model 48-1 general specifications.

Parameter

Output Specifications	10.6 μm	9.3 μm
Wavelength (microns)	10.57–10.63 [†]	9.23–9.31
Power Output ^{1,2}	10 W	8 W
Power Stability ³	$\pm 10\%$	$\pm 15\%$
Mode Quality	$M^2 \leq 1.2$	$M^2 \leq 1.2$
Beam Waist Diameter (at $1/e^2$) ⁴	3.5 mm	3.5 mm
Beam Divergence, full angle	4 mrad	4 mrad
Ellipticity	< 1.2	< 1.2
Polarization	Linear, vertical	Linear, vertical
Extinction ratio	50:1 minimum	50:1 minimum
Rise Time	$< 150 \mu\text{s}$	$< 150 \mu\text{s}$

Electrical Specifications

Power Supply Output

Voltage

30 VDC

Maximum Current

7 A

Control (CTRL) Input

Logic Low (Off State)

0.0 V to +0.5 VDC; 0.0 V nominal

Logic High (On State)

+3.5 V to +10.0 VDC; +5.0 V nominal

Maximum Current Load

6 mA @ +5.0 VDC

Tickle Pulse Signal

Tickle Frequency⁵

5 kHz

Pulse Length

$1.0 \mu\text{s} \pm 0.2 \mu\text{s}$

Pulse Rise/Fall Time

$\leq 100 \text{ ns}$ between +0.5 V to +3.5 VDC

PWM Command Input Signal

PWM Frequency⁶

DC to 20 kHz

PWM Duty Cycle

0% to 100%

* Specifications subject to change without notice.

† Typical. Actual wavelength range may vary from 10.2–10.8 μm .

1 This power level is guaranteed for 12 months regardless of operating hours.

2 Minimum 30 VDC input voltage to obtain guaranteed output power.

3 From cold start (guaranteed) at 95% duty cycle.

4 Measured at laser output.

5 48 Series lasers are designed to operate at a tickle frequency of 5 kHz, which allows the laser to meet published specifications. Tickle frequencies lower than 4.5 kHz may compromise laser performance, particularly optical rise times, and stress the RF electronics thereby reducing long term reliability while tickle frequencies greater than 5 kHz may cause laser emission.

6 FCC and CE tested at 5 kHz.

Technical Reference

Series 48 General Specifications

Model 48-1 general specifications

Parameter

Cooling Specifications ⁷	(Air-cooled)	(Water-cooled)
Maximum Heat Load, laser	300 W	300 W
Minimum Flow Rate	250 CFM × 2 fans.....	0.5 GPM, < 60 PSI
Coolant Temperature	≤ 40 °C, ambient.....	18 °C to 22 °C

Environmental Specifications

Operating Temperature ⁸	15 °C to 40 °C
Humidity.....	0% to 95%, non-condensing

Physical Specifications

Length	16.9 in (42.9 cm)
(incl. cooling tubes).....	18.1 in (46.0 cm)
Width	2.8 in (7.1 cm)
Height	4.2 in (10.7 cm)
Weight	9.0 lbs (4.1 kg)

* Specifications subject to change without notice.

7 Inlet cooling water temperature should always be maintained above the dew point to avoid condensation and water damage to the laser.

8 Published specifications guaranteed at a cooling temperature of 22 °C. Some performance degradation may occur when operated in ambient air or coolant temperatures above 22 °C.

Technical Reference

Series 48 General Specifications

Model 48-2 general specifications

Table 4-10 Model 48-2 general specifications.

Parameter

Output Specifications	10.6 μm	9.3 μm
Wavelength (microns)	10.57–10.63 [†]	9.23–9.31
Power Output ^{1,2}	25 W	18 W
Power Stability ³	$\pm 5\%$	$\pm 7\%$
Mode Quality	$M^2 \leq 1.2$	$M^2 \leq 1.2$
Beam Waist Diameter (at $1/e^2$) ⁴	3.5 mm	3.5 mm
Beam Divergence, full angle	4 mrad	4 mrad
Ellipticity	< 1.2	< 1.2
Polarization	Linear, vertical	Linear, vertical
Extinction ratio	50:1 minimum	50:1 minimum
Rise Time	$< 150 \mu\text{s}$	$< 150 \mu\text{s}$

Electrical Specifications

Power Supply Output

Voltage	30 VDC
Maximum Current	14 A

Control (CTRL) Input

Logic Low (Off State)	0.0 V to +0.5 VDC; 0.0 V nominal
Logic High (On State)	+3.5 V to +10.0 VDC; +5.0 V nominal
Maximum Current Load	6 mA @ +5.0 VDC

Tickle Pulse Signal

Tickle Frequency ⁵	5 kHz
Pulse Length	$1.0 \mu\text{s} \pm 0.2 \mu\text{s}$
Pulse Rise/Fall Time	$\leq 100 \text{ ns}$ between +0.5 V to +3.5 VDC

PWM Command Input Signal

PWM Frequency ⁶	DC to 20 kHz
PWM Duty Cycle	0% to 100%

* Specifications subject to change without notice.

† Typical. Actual wavelength range may vary from 10.2–10.8 μm .

1 This power level is guaranteed for 12 months regardless of operating hours.

2 Minimum 30 VDC input voltage to obtain guaranteed output power.

3 From cold start (guaranteed) at 95% duty cycle.

4 Measured at laser output.

5 48 Series lasers are designed to operate at a tickle frequency of 5 kHz, which allows the laser to meet published specifications. Tickle frequencies lower than 4.5 kHz may compromise laser performance, particularly optical rise times, and stress the RF electronics thereby reducing long term reliability while tickle frequencies greater than 5 kHz may cause laser emission.

6 FCC and CE tested at 5 kHz.

Technical Reference

Series 48 General Specifications

Model 48-2 general specifications

Parameter

Cooling Specifications ⁷	(Air-cooled)	(Water-cooled)
Maximum Heat Load, laser	500 W	500 W
Minimum Flow Rate	250 CFM × 4 fans.....	0.8 GPM, < 60 PSI
Coolant Temperature	≤ 40 °C, ambient.....	18 °C to 22 °C

Environmental Specifications

Operating Temperature ⁸	15 °C to 40 °C
Humidity.....	0% to 95%, non-condensing

Physical Specifications

Length	31.9 in (81.0 cm)
(incl. cooling tubes).....	33.1 in (84.1 cm)
Width	2.8 in (7.1 cm)
Height	4.2 in (10.7 cm)
Weight	18.0 lbs (8.2 kg)

* Specifications subject to change without notice.

7 Inlet cooling water temperature should always be maintained above the dew point to avoid condensation and water damage to the laser.

8 Published specifications guaranteed at a cooling temperature of 22 °C. Some performance degradation may occur when operated in ambient air or coolant temperatures above 22 °C.

Technical Reference

Series 48 General Specifications

Model 48-5 general specifications

Table 4-11 Model 48-5 general specifications.

Parameter

Output Specifications	10.6 μm
Wavelength (microns)	10.57–10.63 [†]
Power Output ^{1,2}	50 W
Power Stability ³	$\pm 5\%$
Mode Quality	$M^2 \leq 1.2$
Beam Waist Diameter (at $1/e^2$) ⁴	3.5 mm
Beam Divergence, full angle	4 mrad
Ellipticity	< 1.2
Polarization	Random
Extinction ratio.....	N/A
Rise Time	$< 150 \mu\text{s}$

Electrical Specifications

Power Supply Output

Voltage.....	30 VDC
Maximum Current	28 A

Control (CTRL) Input

Logic Low (Off State)	0.0 V to +0.5 VDC; 0.0 V nominal
Logic High (On State).....	+3.5 V to +10.0 VDC; +5.0 V nominal
Maximum Current Load.....	12 mA @ +5.0 VDC

Tickle Pulse Signal

Tickle Frequency ⁵	5 kHz
Pulse Length	$1.0 \mu\text{s} \pm 0.2 \mu\text{s}$
Pulse Rise/Fall Time	$\leq 100 \text{ ns}$ between +0.5 V to +3.5 VDC

PWM Command Input Signal

PWM Frequency ⁶	DC to 20 kHz
PWM Duty Cycle	0% to 100%

* Specifications subject to change without notice.

† Typical. Actual wavelength range may vary from 10.2–10.8 μm .

1 This power level is guaranteed for 12 months regardless of operating hours.

2 Minimum 30 VDC input voltage to obtain guaranteed output power.

3 From cold start (guaranteed) at 95% duty cycle.

4 Measured at laser output.

5 48 Series lasers are designed to operate at a tickle frequency of 5 kHz, which allows the laser to meet published specifications. Tickle frequencies lower than 4.5 kHz may compromise laser performance, particularly optical rise times, and stress the RF electronics thereby reducing long term reliability while tickle frequencies greater than 5 kHz may cause laser emission.

6 FCC and CE tested at 5 kHz.

Technical Reference

Series 48 General Specifications

Model 48-5 general specifications

Parameter

Cooling Specifications^{7,8} (Water-cooled)

Maximum Heat Load, laser 800 W

Minimum Flow Rate 1.5 GPM, < 60 PSI

Coolant Temperature 18 °C to 22 °C

Environmental Specifications

Operating Temperature⁹ 15 °C to 40 °C

Humidity 0% to 95%, non-condensing

Physical Specifications

Length 34.9 in (88.6 cm)

(incl. cooling tubes) 36.4 in (92.5 cm)

Width 5.3 in (13.5 cm)

Height 4.5 in (11.4 cm)

Weight 44.0 lbs (20.0 kg)

* Specifications subject to change without notice.

7 Lasers with output power ≥ 50 W must be water-cooled. Lasers with output < 50 W can be water- or air-cooled although water-cooling is strongly recommended for duty cycles > 50%. Water-cooling improves power stability at any duty cycle.

8 Inlet cooling water temperature should always be maintained above the dew point to avoid condensation and water damage to the laser.

9 Published specifications guaranteed at a cooling temperature of 22 °C. Some performance degradation may occur when operated in ambient air or coolant temperatures above 22 °C.

Note: Series 48™ lasers are tested to meet published specifications at an input voltage of 30.0 VDC.

Technical Reference

48 Series Drawings

Technical Drawings

Note: Series 48 lasers may be hard-mounted to equipment by removing several of the bottom panel screws and replacing these with longer screws to secure the laser to optical assemblies. This mounting method is only recommended as long as the screws do not support the weight of the laser. For a sturdier attachment, the laser may be clamped to optical assemblies by applying clamping forces between top and bottom cover screws. Do not apply clamping forces on the longitudinal centerline.

Technical Reference

48 Series Drawings

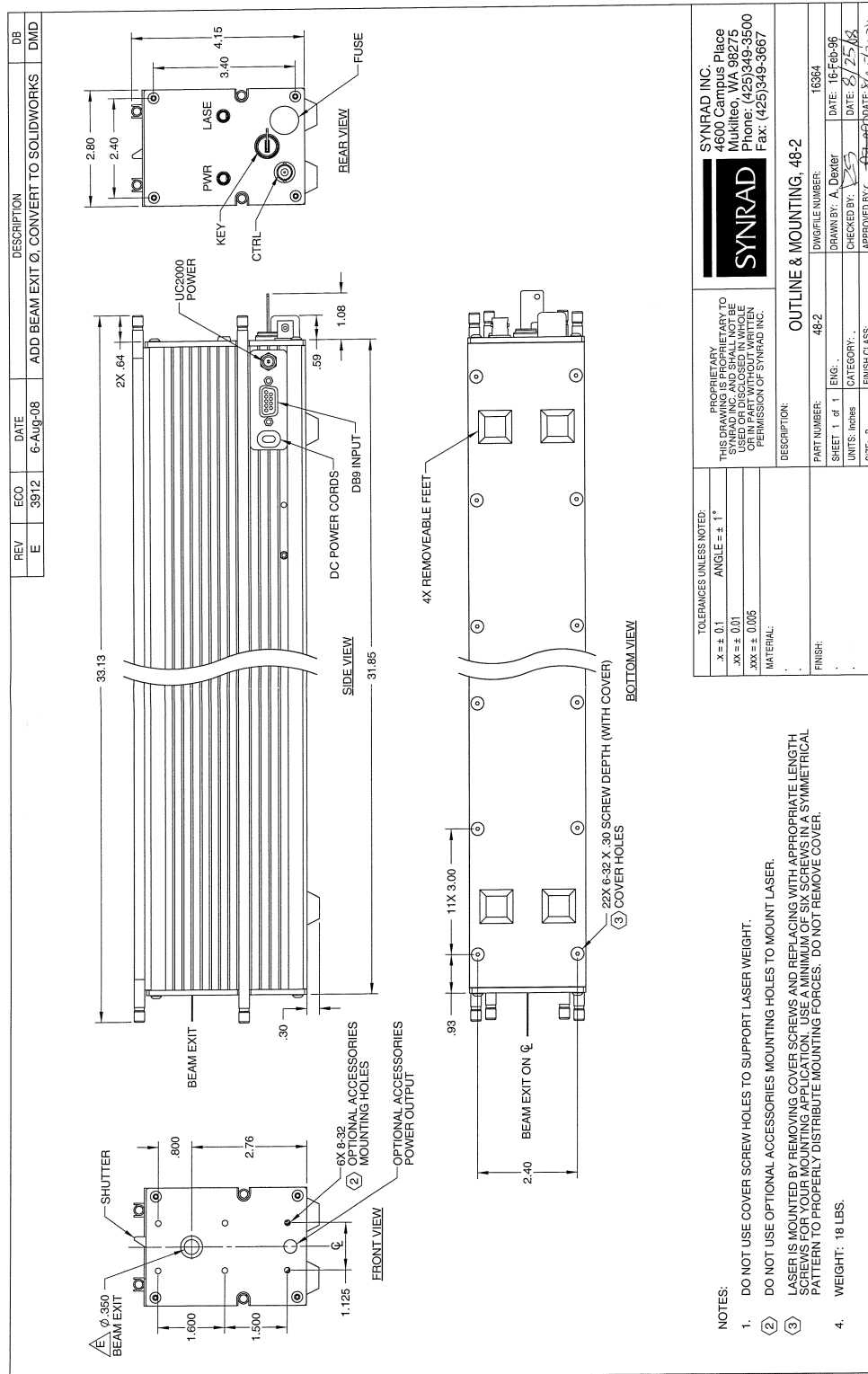

Figure 4-15 Model 48-2 package outline and mounting dimensions, 2 of 2.

Technical Reference

48 Series Drawings

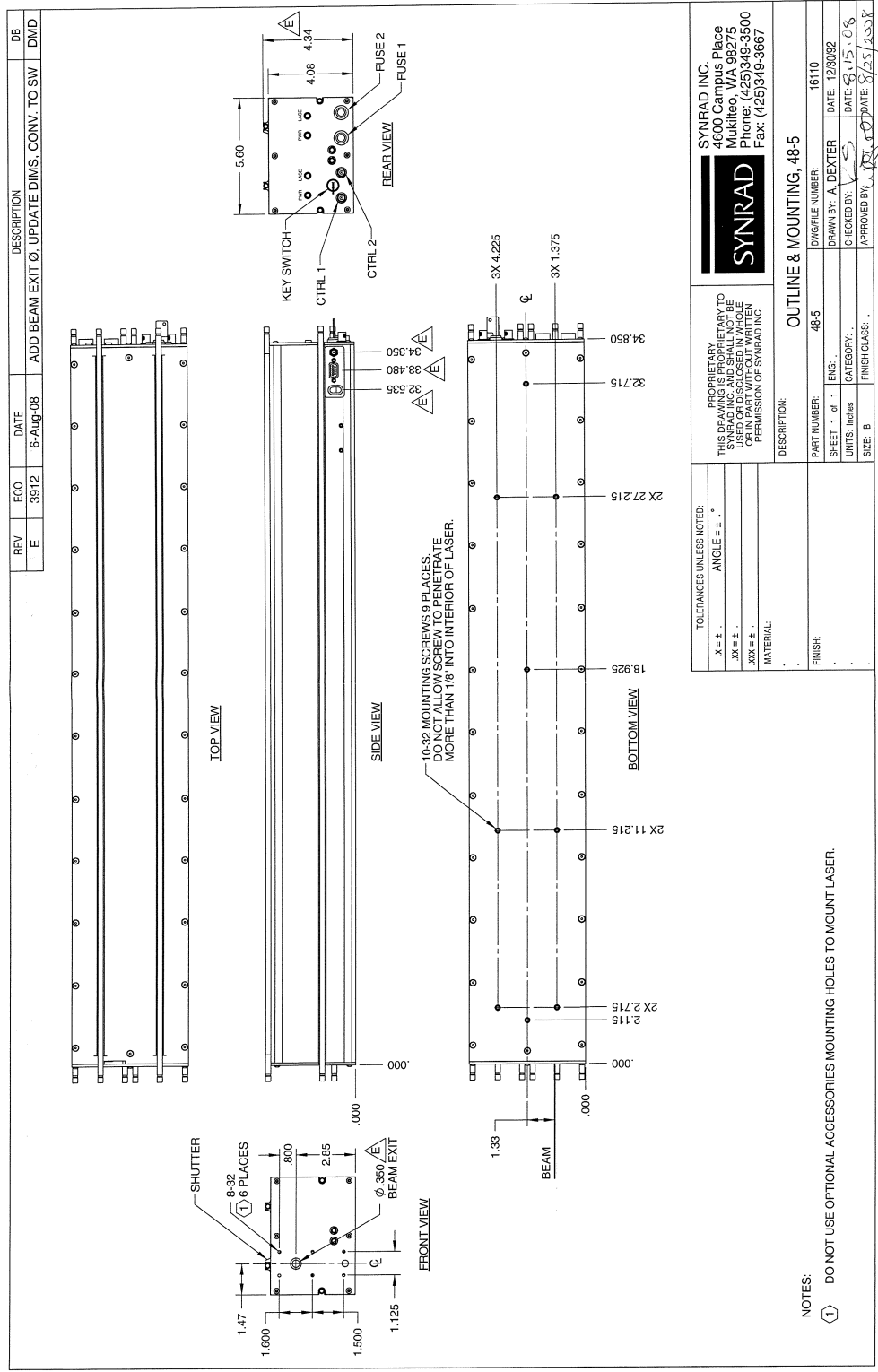

Figure 4-16 Model 48-5 package outline and mounting dimensions.

Technical Reference

48 Series Drawings

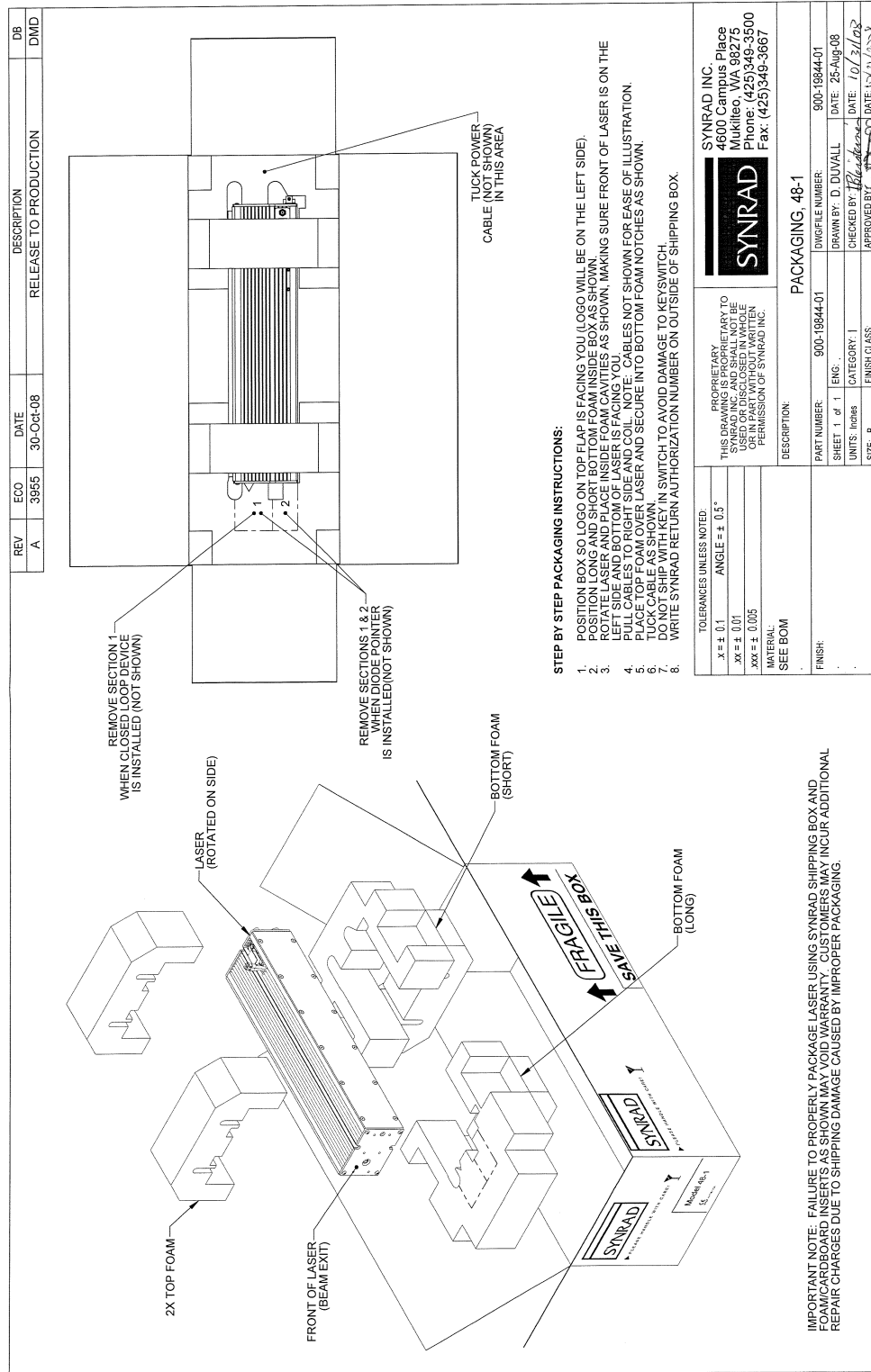

Figure 4-17 Model 48-1 packaging instructions.

Technical Reference

48 Series Drawings

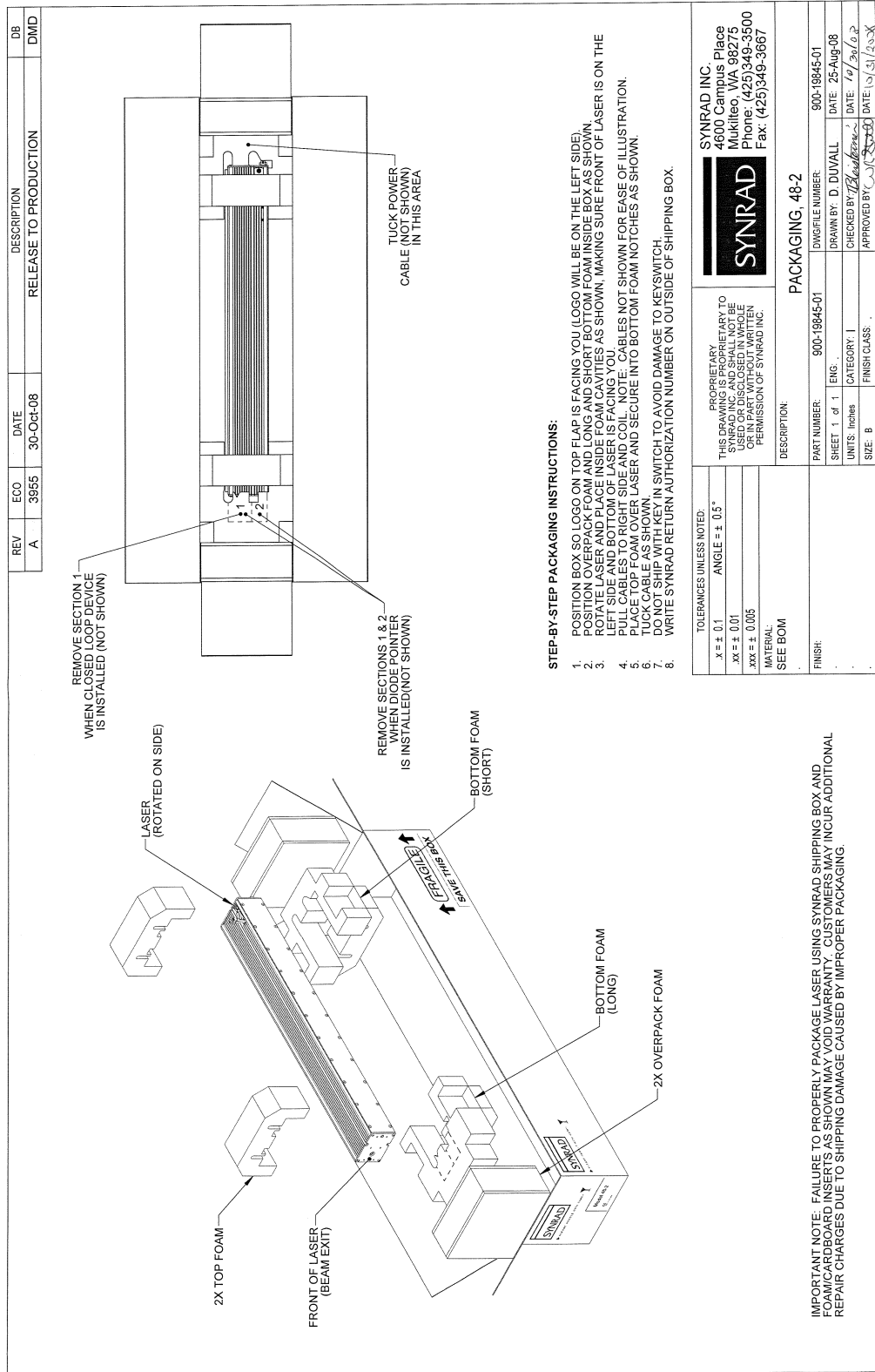

Figure 4-18 Model 48-2 packaging instructions.

Technical Reference

48 Series Drawings

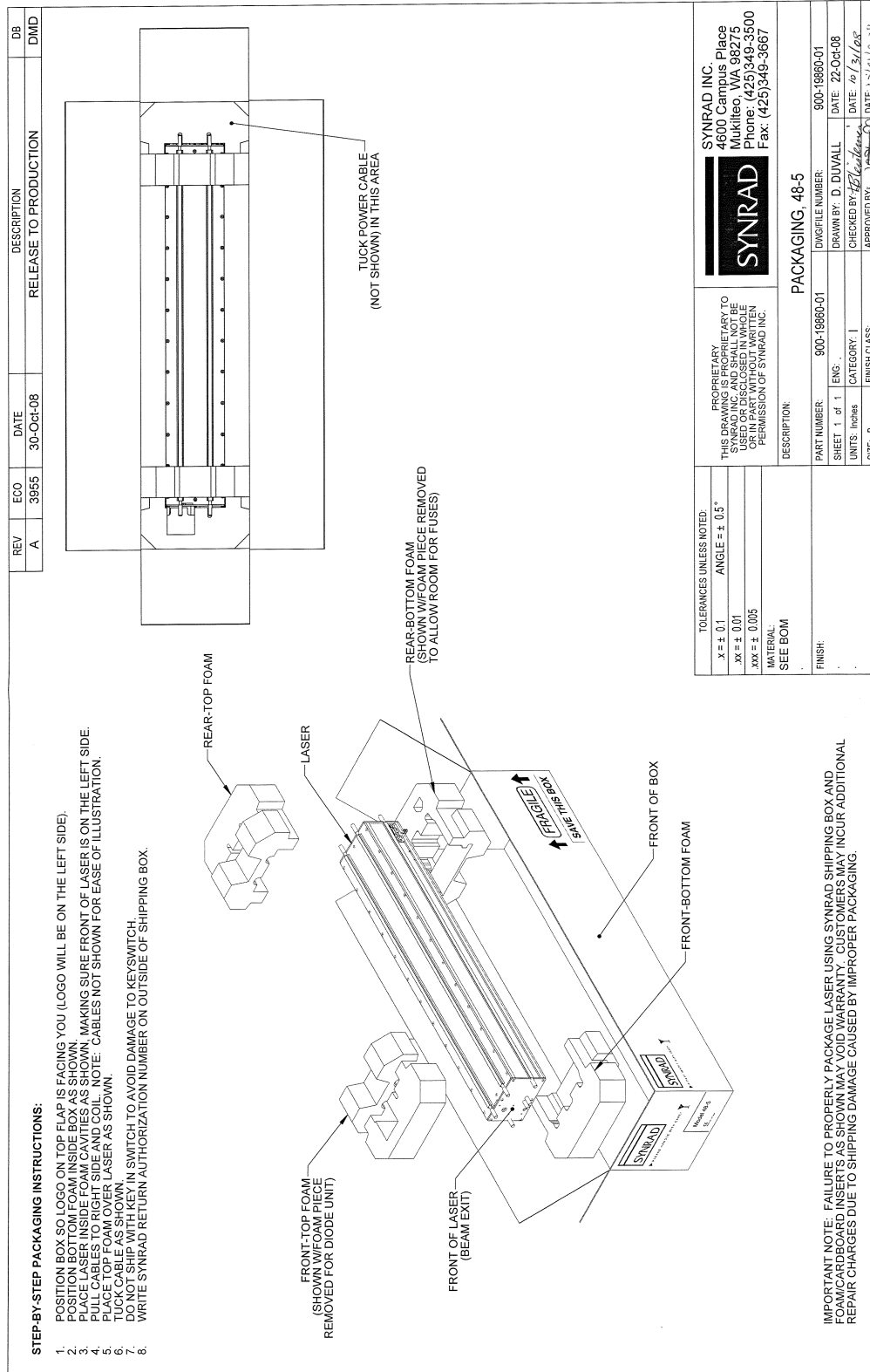

Figure 4-19 Model 48-5 packaging instructions.

Technical Reference

48 Series Drawings

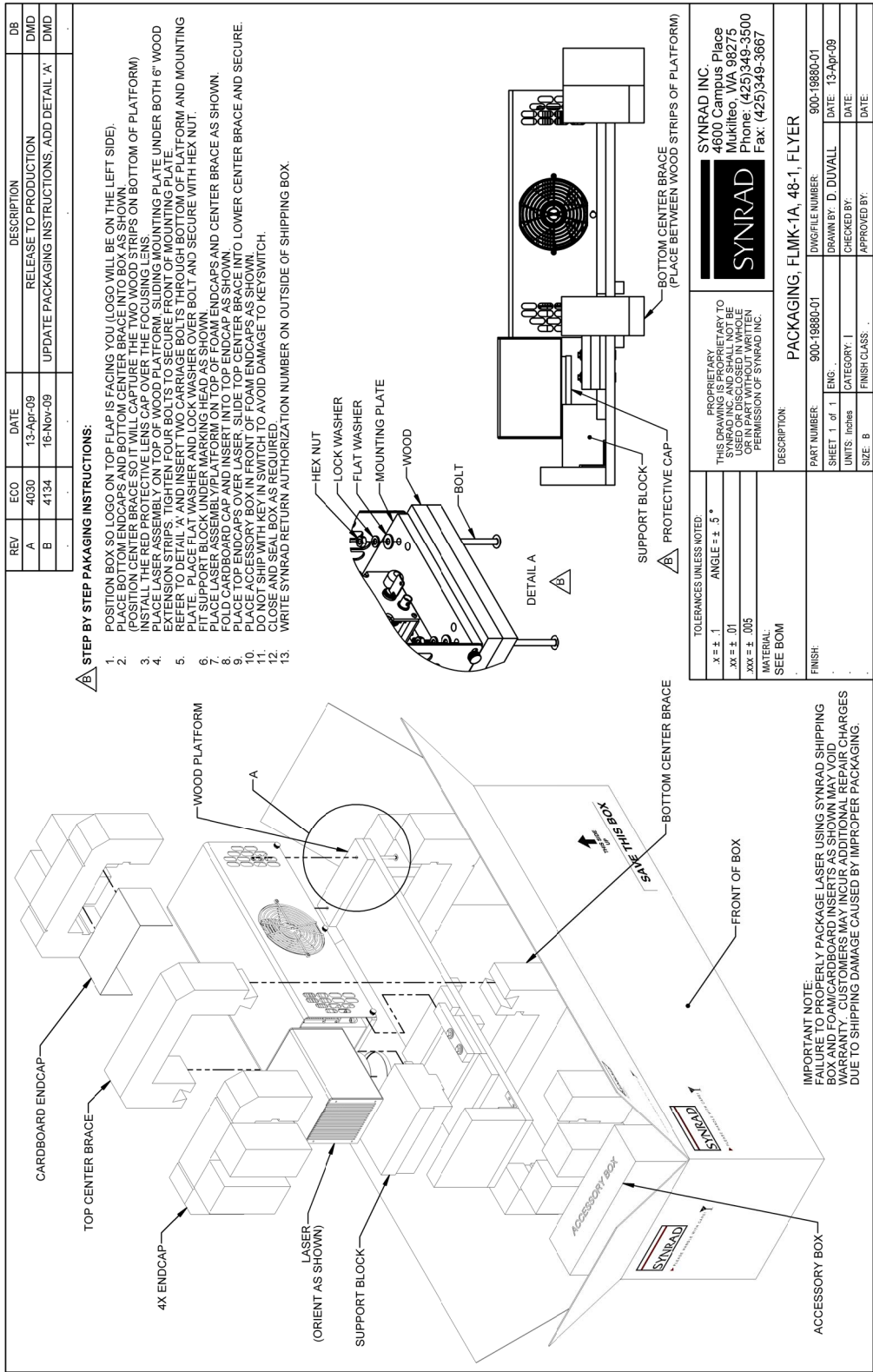

Figure 4-20 FLMK-1A (10W fan shroud) packaging instructions.

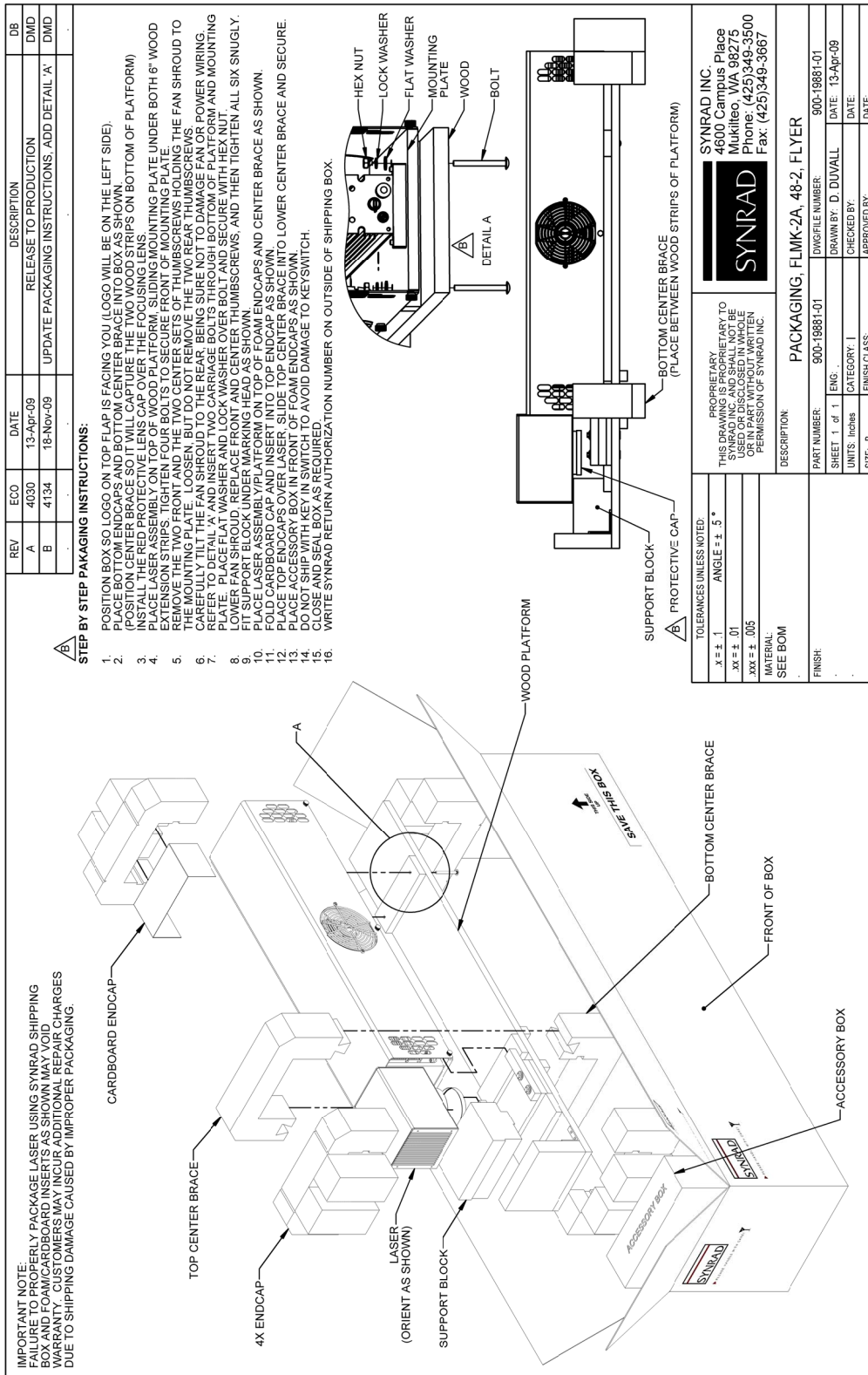

Figure 4-21 FLMK-2A (25W fan shroud) packaging instructions.

Maintenance/ Troubleshooting

Maintenance

5

Maintenance and Troubleshooting

Introduction

- Maintenance – describes typical 48 series maintenance procedures.
- Troubleshooting – explains how to troubleshoot common 48 series problems.

**Important
Note:**



This section of the Operation Manual explains how to conduct regular maintenance and/or basic troubleshooting to series 48 lasers. If you cannot attend to the unit using the information described in this manual, contact SYNRAD®, (+.425.349.3500) or an authorized SYNRAD Distributor.

**Warning
Serious
personal
injury**



All Class 4 laser product that emit invisible infrared laser radiation in the 9.3–10.6 μm CO₂ wavelength band are capable of seriously burning human tissue.

Because direct or diffuse laser radiation can inflict severe corneal injuries, always wear eye protection when in the same area as an exposed laser beam.

Do not allow the laser beam to contact a person.

This product emits an invisible laser beam that is capable of seriously burning human tissue.

Always be aware of the beam's path and always use a beam block while testing.

A risk of exposure to toxic elements, like zinc selenide, may result when certain optical or beam delivery components are damaged.

In the event of damage to the laser or beam delivery optics, contact SYNRAD or the optics manufacturer for handling instructions.

The use of aerosol dusters containing difluoroethane causes "blooming", a condition that significantly expands and scatters the laser beam. This beam expansion can affect mode quality and/or cause laser energy to extend beyond the confines of optical elements in the system, possibly damaging acrylic safety shielding. Do not use air dusters containing difluoroethane in any area adjacent to CO₂ laser systems because difluoroethane persists for long time periods over wide areas.

Maintenance/ Troubleshooting

Maintenance

Maintenance

- Disabling the series 48 laser
- Daily inspections
- Storage/shipping
- Cleaning optical components

Disabling the Series 48™ Laser

Before performing any maintenance on your 48 series laser, be sure to completely disable the laser by disconnecting the DC Power Cables from the DC power supply.

Daily inspections

Perform the following steps daily to keep your 48 series laser in optimum operating condition. Except for the procedures described below, no other service is required or should be attempted.

Caution **Possible** **Equipment** **Damage**



Even small amounts of contamination on optics in the beam path can absorb enough energy to damage the optic. Inspect beam delivery optics periodically for signs of contaminants and carefully clean as required. In dirty environments, purge laser optics using filtered air or nitrogen to prevent vapor and debris from accumulating on optical surfaces.

If you operate the laser in dirty or dusty environments, contact SYNRAD® about the risks of doing so and precautions you can take to increase the longevity for the laser system and associated optical components.

- 1 Inspect all cooling tubing connections for signs of leakage. Check for signs of condensation that may indicate the cooling water temperature has been set below the dew point temperature. Condensation will damage electrical and optical components inside the laser. See the Setting coolant temperature section in the Getting Started chapter for details on preventing condensation.
- 2 When using compressed air as a purge gas on your series 48 laser, empty water traps and oil separators on each filter and/or dryer between the laser and your compressed air source. Compressed air purity must meet the purge gas specifications shown in the Getting Started chapter.

Maintenance/ Troubleshooting

Maintenance

- 3 Inspect beam delivery components for signs of dust or debris and clean as required. When cleaning the optical surfaces of beam delivery components, carefully follow the manufacturer's instructions.
- 4 Visually inspect the exterior housing of the laser to ensure that all warning labels are present. Refer to the Laser Safety chapter for 48 series label types and locations.

Storage/shipping

Refer to Packaging instructions in the Technical Reference chapter and/or appropriate quick start guide for detailed instructions on properly packaging the laser for shipment.

In cold climates, any water left in the cooling system may freeze, which could damage internal components. After draining thoroughly, use compressed shop air at no more than 200 kPa (29 PSI)—Wear safety glasses!—to remove any residual water. When finished, cap all connectors to prevent debris from entering the cooling system.

If you no longer have the original shipping box and inserts, contact SYNRAD Customer Service about purchasing replacement packaging.

Important Note:



Failure to properly package the laser using SYNRAD-supplied shipping boxes and foam/cardboard inserts as shown in the Packaging instructions may void the warranty. Customers may incur additional repair charges for shipping damage caused by improper packaging.

Warning Serious personal injury

Ensure that DC power to the laser is turned off and locked out before inspecting optical components in the beam path.

Invisible CO₂ laser radiation is emitted through the aperture. Corneal damage or blindness may result from exposure to laser radiation.



Coolants

SYNRAD® recommends that the laser's cooling fluid contain at least 90% distilled water by volume. In closed-loop systems, use a corrosion inhibitor/algaecide such as Optishield® Plus or equivalent as required. Avoid glycol-based additives because they reduce the coolant's heat capacity and high concentrations may affect power stability. Refer to the cooling specifications and the dew point table located in the Technical Reference chapter of this manual. Glycol is not necessary unless the chiller is subjected to freezing temperatures. If tap water is used, chloride levels should not exceed a concentration of 25 parts per million (PPM) and total hardness should be below 100 PPM. Install a filter on the chiller's return line and inspect frequently.

Maintenance/ Troubleshooting

Maintenance

Caution

DO NOT use de-ionized (DI) water as a coolant!

Possible Equipment Damage

DI water is unusually corrosive and is not recommend for mixed material cooling systems.



Operating the laser at coolant temperatures above 22 °C (72 °F) may result in decreased performance and/or premature failure of electronic components.

Do not exceed coolant pressure of 414 kPa (60 PSI)!

Inlet cooling water temperature must always be maintained above the dew point temperature to prevent condensation and water damage to your laser.

Even small amounts of contamination on optics in the beam path can absorb enough energy to damage the optic.

Inspect beam delivery optics periodically for signs of contaminants and carefully clean as required.

In dirty environments, purge laser optics using filtered air or nitrogen to prevent vapor and debris from accumulating on optical surfaces.

To use the following dew point table, look down the Air Temp column and locate an air temperature in Fahrenheit or Celsius (°C values are shown in parentheses) that corresponds to the air temperature in the area where your laser is operating. Follow this row across until you reach a column matching the relative humidity in your location. The value at the intersection of the Air Temp and Relative Humidity columns is the Dew Point temperature in °F (or °C). The chiller's temperature setpoint must be set above the dew point temperature.

For example, if the air temperature is 85 °F (29 °C) and the relative humidity is 60%, then the dew point temperature is 70 °F (21 °C). Adjust the chiller's temperature setpoint to 72 °F (22 °C) to prevent condensation from forming inside the laser.

Refer to the dew point temperature table within the prior chapter for a range of air temperature and relative humidity values. Remember that the laser's coolant temperature must be set above the dew point temperatures shown in the chart, but should not exceed the environmental specifications located in the Series 48 General Specifications within the Technical References chapter of this manual.

Maintenance/ Troubleshooting

Maintenance

Debris or contaminants on the laser's output coupler or external beam delivery components may affect laser processing and lead to damage or failure of the optics and/or the laser. Carefully follow the steps below to inspect and clean the optical components in the beam path. Before beginning the cleaning process, read this entire section thoroughly to ensure that all cleaning materials are available and that each step is completely understood.

**Important
Note:**



Exercise great care when handling infrared optics; they are much more fragile than common glass materials. Optical surfaces and coatings are easily damaged by rough handling and improper cleaning methods.

Cleaning guidelines

- Wear latex gloves or finger cots (powder-free) to prevent contamination of optical surfaces by dirt and skin oils.
- Never handle optics with tools; always use gloved hands or fingers.
- Hold optics by the outer edge; never touch the coated surface.
- Always place optics lens on a tissue or suitable equivalent material for protection; never place optics on hard or rough surfaces.
- It may be necessary to use a cotton ball or fluffed cotton swab instead of a lens wipe to uniformly clean the entire surface of small-diameter mounted optics.
- Before using any cleaning agents, read Material Safety Data Sheets (MSDS) and observe all necessary safety precautions.

Required cleaning materials

The table below lists the type and grade of materials required to properly clean optical surfaces.

Table 5-1 Required cleaning materials.

Cleaning Material	Requirements
Latex gloves or finger cots	Powder free
Air bulb	Clean air bulb
Ethyl or isopropyl alcohol	Spectroscopic or reagent grade
Acetone	Spectroscopic or reagent grade
Lens wipe (preferred)	Optical (cleanroom) quality
Cotton balls or cotton swabs	High-quality surgical cotton/high-quality paper-bodied

Maintenance/ Troubleshooting

Maintenance

Cleaning optics

- 1 Shut off and lock out all power to the laser. You must verify that the laser is OFF (in a zero-energy state) before continuing with the optical inspection!
- 2 Visually inspect all optical surfaces in the beam path for contaminants.
- 3 Remove loose contaminants from the optic by holding a clean air bulb at an angle to the optic and blow a stream of air at a glancing angle across the lens surface. Repeat as necessary.
- 4 Dampen a lens wipe with the selected cleaning agent. Alcohol (least aggressive) is best for initial surface cleaning. Acetone (moderately aggressive) is best for oily residue or minor baked-on vapors and debris.
- 5 Gently, and without applying pressure, drag the damp lens wipe across the optical surface in a single pass. Do not rub or apply any pressure, especially when using a cotton swab. Drag the wipe without applying any downward pressure.
- 6 Carefully examine the optic under suitable lighting. Certain contaminants or damage such as pitting cannot be removed. In these cases the optic must be replaced to prevent catastrophic failure.
- 7 Repeat Steps 4 through 6 as required, removing all traces of contaminants and depos-

Important Note:



If acetone is used as a cleaning solvent, a second follow-up cleaning of the optical surface using alcohol is required to remove any acetone residue.

Use a clean lens wipe on each pass. The wipe will pick up and carry surface contaminants that may scratch optical surfaces or coatings if reused.

Caution Possible Equipment Damage



Do not allow the nozzle of the air bulb to touch the optical surface. Any contact may damage the optic by scratching coatings on the optical surface.

Do not use compressed shop air to blow contamination from the optic. Compressed air contains significant amounts of water and oil that form adsorbing films on the optical surface.

Do not exert pressure on the surface of the optic during cleaning. Optical surfaces and coatings are easily scratched by dislodged contaminants.

Use a **new lens wipe on each pass** as contaminants picked up by the wipe may scratch the optical surface.

Maintenance/ Troubleshooting

Troubleshooting

Troubleshooting

- Introduction
- Resetting faults
- Laser faults
- Beam delivery optics

Troubleshooting Introduction

This section is designed to help isolate problems to the module level only. Problems on circuit boards or the laser tube are not within the scope of this guide because they are not user-serviceable assemblies; do not attempt to repair them. Contact SYNRAD® or a SYNRAD Authorized Distributor for repair or replacement information.

To troubleshoot the Series 48™ laser, it is necessary to understand the sequence of events that must happen before the laser can turn on and operate. Before you attempt to perform any service, we advise you to read the entire troubleshooting guide and review the relevant schematic diagrams. Symptoms and possible causes are highlighted by dark print and bullet points throughout this section. Information about each symptom and cause can be found in the paragraphs following each heading.

Caution

Possible Equipment Damage



Attempting repair of a SYNRAD laser without the express authorization of SYNRAD, will void the product warranty. If troubleshooting or service assistance is required, please contact SYNRAD Customer Service.

Operating the laser at coolant temperatures above 22 °C (72 °F) may result in decreased performance and/or premature failure of electronic components.

Do not exceed coolant pressure of 414 kPa (60 PSI)!

Maintenance/ Troubleshooting

Troubleshooting

Resetting faults

Keyswitch lasers

On Keyswitch lasers, the PWR indicator illuminates green only when the Remote Interlock input is closed and the Keyswitch is cycled from OFF to the ON position (or the Remote Keyswitch input is opened and then closed). After the PWR indicator illuminates, a five-second delay occurs before the laser is permitted to lase. The LASE LED illuminates dimly when tickle pulses are applied to the laser and when PWM Command pulses are applied (and are long enough to produce laser output) the LASE LED illuminates and appears to brighten in relation to an increasing PWM duty cycle.

To reset a remote interlock fault after the fault condition has been cleared, the Keyswitch must be cycled from OFF to ON (or with the Keyswitch ON, cycle the Remote Keyswitch input open and then closed). When the PWR indicator illuminates, lasing is enabled after the five-second delay.

To reset an over temperature fault, lower coolant temperature below 22 °C (water-cooled) or below 40 °C (air-cooled). When the laser cools sufficiently, remove DC power for 30 seconds and then reapply power to the laser or cycle the Keyswitch from OFF to ON (or with the Keyswitch ON, cycle the Remote Keyswitch input open and then closed). When the PWR indicator illuminates, lasing is enabled after the five-second delay.

A closed shutter is not considered a fault condition; when the shutter is opened, lasing is enabled provided the PWR indicator is illuminated green.

After a power failure or shutdown has occurred, the Power-On Reset feature will not allow lasing to restart until the Keyswitch or Remote Keyswitch is first cycled off (open circuit condition) and then back on (closed circuit).

During any fault shutdown, the Fault Shutdown Output (Pin 1 on the DB-9 Connector), which is normally at +15 VDC, latches to a low state (0 VDC) until a keyswitched reset occurs.

OEM lasers

On OEM lasers, the PWR lamp illuminates on DC power-up. After the PWR indicator illuminates, a five-second delay occurs before the laser is permitted to lase. The LASE LED illuminates dimly when tickle pulses are applied to the laser and when PWM Command pulses are applied (and are long enough to produce laser output) the LASE LED illuminates and appears to brighten in relation to an increasing PWM duty cycle.

To reset an over temperature fault, the coolant temperature must be lowered below 22 °C (water-cooled) or below 40 °C (air-cooled). When the laser cools sufficiently, remove DC power for 30 seconds and then reapply power to the laser or toggle (open, then close) the Remote Keyswitch signal via Pin 6 and Pin 7 on the DB-9 Connector. When the PWR indicator illumi-

Maintenance/ Troubleshooting

Troubleshooting

Operational flowchart

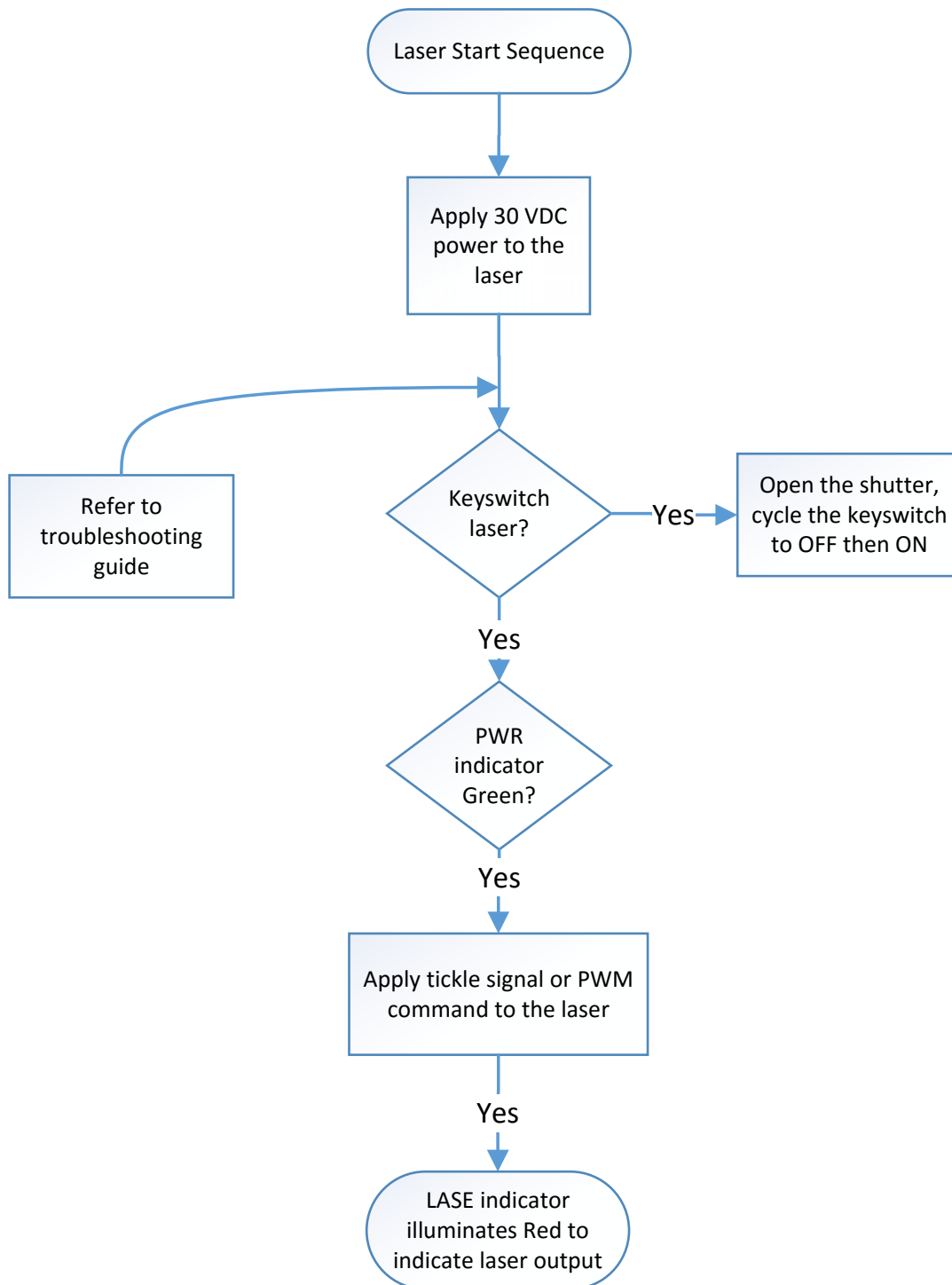

Figure 5-1 48 series™ operational flowchart.

Maintenance/ Troubleshooting

Troubleshooting

nates, lasing is enabled after the five-second delay.

The Power-On Reset feature is not available on OEM models; OEM customers must provide this required safety feature as part of their equipment integration.

During any fault shutdown, the Fault Shutdown Output (Pin 1 on the DB-9 Connector), which is normally at +15 VDC, latches to a low state (0 VDC) until the laser is reset by removing DC power for 30 seconds and then reapplying power to the laser.

Each Symptom listed below describes a particular fault condition. For each Symptom, specific causes and solutions are described in the Possible Causes section.

Symptom:

- There is no output laser beam; PWR and LASE indicators are off.

Possible Causes & Solutions:

- No DC voltage is applied or the voltage level is out of specification.

Check that +30 VDC is available on the power supply output terminals and ensure that DC Power cable terminal connections are tight.

Check the fuse(s) on the rear of the laser. Replace with fast-blow 10 Amp (48-1) or 20 Amp (48-2/48-5) AGC/3AG fuses (rated at 32 V minimum) as required.

- A reverse DC voltage was applied to the laser.

Replace the fuse(s) with a fast-blow 10 Amp (48-1) or 20 Amp (48-2/48-5) AGC/3AG fuse (rated at 32 V minimum) as required.

- The laser's DB-9 Connector is not configured correctly.

Ensure that the factory-wired DB-9 jumper plug is firmly plugged into the laser's DB-9 Connector.

If the laser is connected through the DB-9 Connector to external circuits, check that field wiring is correct. The remote interlock connection (Pin 3) must be grounded through your external interlock circuit to Pin 2 or Pin 4. Pin 6 must be connected to Pin 7 through your external keyswitch circuitry. Refer to Connecting in the Getting Started chapter and DB-9 connections in the Technical Reference chapter for details. A quick method to isolate the problem to either the laser or the field wiring is to disconnect field wiring and plug in the factory-wired jumper plug; if the lasers operates normally with the jumper plug installed, verify external wiring and circuit devices.

- The laser's Keyswitch is not set properly.

Maintenance/ Troubleshooting

Troubleshooting

Cycle the Keyswitch to the OFF position for a few seconds, then cycle back to ON.

- The laser is in an over temperature condition.

Allow the laser to cool. Verify that the laser is receiving the proper air or water flow per the following table. On air-cooled lasers, verify fan operation and check for at least 57.2 mm (2.25 in) of unobstructed clearance around the fan housing. To restart the laser, disconnect DC power, wait 30 seconds, and then reapply DC power.

Table 5-2 Series 48™ cooling specifications.

Model	Air-cooled	Water-cooled
48-1	7.1 m ³ /min × 2 fans (1 per side) 250 CFM × 2 fans (1 per side)	1.9 LPM at < 414 kPa 0.5 GPM at < 60 PSI
48-2	7.1 m ³ /min × 4 fans (2 per side) 250 CFM × 4 fans (2 per side)	3.0 LPM at < 414 kPa 0.8 GPM at < 60 PSI
48-5	N/A N/A	5.7 LPM at < 414 kPa 1.5 GPM at < 60 PSI

Symptom:

- No output beam and the PWR and LASE LEDs are Off, but +30 VDC is applied.

Possible Causes:

- A fault shutdown has occurred. Pin 1 on the DB-9 Connector is at 0 VDC in reference to Pin 2 or Pin 4 (Pin 1 is at +15 VDC during normal operation).

An over temperature, overvoltage/undervoltage, or RF circuitry failure has occurred.

Correct the problem(s), then remove power from the laser for 30 seconds. Re-apply power (on Keyswitch lasers, cycle the Keyswitch or Remote Keyswitch).

Symptom:

- No output beam, the PWR LED is On, but the LASE indicator is off.

Possible Causes:

- The Shutter Switch is closed or not fully open.

Maintenance/ Troubleshooting

Troubleshooting

Close and then re-open the Shutter Switch.

Symptom:

- No output beam, but the PWR LED is On. The LASE indicator is dim and does not brighten.

Possible Causes:

- A PWM Command input signal is not present.

Verify that a PWM Command signal is present on the CTRL input. On 48-5 dual-tube lasers, a Command signal must be applied to both CTRL1 and CTRL2 inputs simultaneously. See Controlling laser power in the Technical Reference chapter for PWM Command signal details.

Symptom:

- Laser power varies or responds intermittently to input PWM Command pulses.

Possible Causes:

- Verify that your UC-2000 or equivalent PWM controller is delivering tickle pulses of the proper duration. See Controlling laser power in the Technical Reference chapter for tickle pulse details.

Maintenance/ Troubleshooting

Troubleshooting

Status LEDs

LASER CONDITION / FAULT	INPUT STATUS			LED STATUS	OUTPUT STATUS				COMMENTS
	Remote Key	Remote Interlock	PWM		Fault Shutdown	Message	Remote Ready	Remote Lase	
Connector & pins	DB-9: 6 to 7	DB-9: 3 to 4	BNC		DB-9 pin 1	DB-9 pin 5	DB-9 pin 9	DB-9 pin 8	Outputs ref'd to pins 2,4 of DB-9
DC Power Off	X	X	X	PWR <input type="radio"/> LASE <input type="radio"/>	H				No RF to tube
DC Power Applied Laser Not Enabled	O	X	X	PWR <input type="radio"/> LASE <input type="radio"/>	H	H	ON		No RF to tube
	X	O	X	PWR <input checked="" type="radio"/> LASE <input type="radio"/>	H	H	ON		RF enabled
Laser enabled, no tickle or PWM	C	C	None	PWR <input checked="" type="radio"/> LASE <input type="radio"/>	H	H	ON		RF enabled
Tickle Applied	C	C	Tickle	PWR <input checked="" type="radio"/> LASE <input type="radio"/>	H	H	ON	Tickle	RF enabled
Laser Firing	C	C		PWR <input checked="" type="radio"/> LASE <input type="radio"/>	H	H	ON		LASING!
Shutter Closed*	C	C	X	PWR <input checked="" type="radio"/> LASE <input type="radio"/>	H	H	ON		No RF to tube
Keyswitch in OFF position*	X	X	X	PWR <input type="radio"/> LASE <input type="radio"/>	H	H			No RF to tube
Tube nearing overtemp	C	C		PWR <input checked="" type="radio"/> LASE <input type="radio"/>	H	L			Internal temp > 54°C
Over Temp Fault	X	X	X	PWR <input type="radio"/> LASE <input type="radio"/>	L	L			Internal temp > 60°C
Under Voltage Fault	X	X	X	PWR <input type="radio"/> LASE <input type="radio"/>	L	L			Voltage below 28VDC
Over Voltage Fault	X	X	X	PWR <input type="radio"/> LASE <input type="radio"/>	L	L			Voltage above 32VDC
TABLE KEY: *Keyswitch lasers only	C = circuit closed O = circuit open X = Does not matter			Brightness of Lase LED = PWM duty cycle	L = output low H = output high/open				

Table 5.3 48 series™ Input/Output & LED Status Signals.

Maintenance/ Troubleshooting

Troubleshooting

Beam delivery optics

Symptom:

- The laser appears to slowly lose power over time; laser output power must be increased to maintain previous performance.

Possible Causes:

- Beam delivery optics are coated by vapor residue or debris.

Symptom:

- The laser appears to slowly lose power over time; laser output power must be increased to maintain previous performance.

Possible Causes:

- Beam delivery optics are coated by vapor residue or debris.

Shut down the laser and carefully inspect each optic in the beam delivery path, including the laser's output coupler. Remember that optics are fragile and must be handled carefully; preferably by the mounting ring only. If the optic requires cleaning, refer to the required cleaning materials table earlier in this chapter, then refer back to Maintenance for cleaning instructions. Use only recommended cleaning materials to prevent scratching delicate optical surfaces.

If the focusing optic is pitted, it must be replaced immediately. The laser's high power density will cause pits or debris on the lens to absorb enough energy that the lens may crack. If this happens, other optics in the beam path may be contaminated or damaged as well.

When the application requires air (instead of nitrogen or argon) as an assist gas, we recommend the use of breathing quality air available in cylinders from a welding supply company. Because compressed shop air contains minute particles of oil and other contaminants that will damage optical surfaces, it must be carefully filtered and dried before use as a purge or assist gas. Refer to Assist gas purity specifications, in the Technical Reference chapter for filtering specifications.

Caution **Possible** **Equipment** **Damage**



If you operate your laser or marking head in a dirty or dusty environment, contact SYNRAD® about the risks of doing so and the precautions you can take to increase the longevity of your laser.

Chapter Index

A

American National Standards Institute (ANSI) [18](#)
 Assist gas purity
 specifications, [35](#), [40](#), [41](#)

C

Caution
 condensation, [5](#), [15](#), [27](#), [33](#), [42](#), [50](#), [60](#), [62](#), [83](#), [85](#), [86](#), [93](#)
 voiding warranty, [81](#)
 CDRH [21](#)
 Chiller
 temperature setpoint, [37](#)
 Class IV safety features [24](#)
 Code of Federal Regulations (CFR) [21](#), [22](#)
 Command signal [50](#)
 Condensation damage [81](#)
 Customer Service [8](#)

D

Daily inspections [81](#)
 DC Power cable [81](#)
 Dew point
 chart, [53](#)
 Disabling Firestar [81](#)

F

Flowchart
 laser start-up, [88](#)
 Food and Drug Administration (FDA) [21](#)

H

Hazard information [15](#)
 label locations, [20](#)
 terminology, [15](#)

I

Inspections
 daily, [81](#)

L

Label locations [20](#)
 Laser Institute of America (LIA) [19](#)

M

Maintenance
 daily inspections, [81](#)
 disabling Firestar, [81](#)
 storage/shipping, [82](#)
 MSDS [84](#)

O

Occupational Safety and Health Administration (OSHA) [19](#)

R

Reference materials [8](#)
 RoHS [23](#)

S

Sales and Applications [8](#)
 Specifications
 assist gas purity, [35](#), [40](#), [41](#)
 Storage/shipping [82](#)

T

Technical Support [8](#)
 Trademark information [6](#)
 Troubleshooting [84](#)
 operational flowchart, [88](#)

U

User I/O
 connection summary, [53](#)
 User I/O connections
 input/output signals [53](#)

W

Warning
 laser radiation, [81](#)
 Warranty information [7](#)

Tables and Figures

Figure 1-1 Series 48™ ship kit contents.	11
Table 1-1 Series 48 ship kit contents.	11
Figure 1-2 Anatomy of a model number.	13
Figure 2-1 Labeling terms and definitions.	15
Figure 2-2 Always wear safety glasses.	17
Figure 2-1 48-1 Hazard label locations.	19
Figure 2-2 48.2 Hazard label locations.	20
Figure 2-3 48-5 Hazard label locations.	21
Table 2-3 Class 4 safety features.	25
Table 2-4 European Union Directives.	26
Figure 2-4 European compliance mark.	26
Figure 2-5 48 Series Declaration Document.	27
Figure 3-1 48-1/48-2 Front panel.	29
Figure 3-2 48-1/48-2 Rear panel.	30
Figure 3-3 Side panel controls and indicators. ...	31
Figure 3-4 48-5 Front panel.	32
Figure 3-5 48-5 Back panel.	33
Figure 4-1 Beam characteristics.	36
Figure 4-2 “Flying optics” beam path.	42
Table 4-2 Assist gas purity specifications.	43
Table 4-3 Input signal specifications.	44
Table 4-4 Tickle pulse specifications.	45
Figure 4-3 Tickle pulse waveform.	45
Figure 4-4 Series 48-2 kHz waveform.	46
Figure 4-5 Series 48-5 kHz waveform.	47
Table 4-5 PWM Command signal specifications.	49
Figure 4-6 PWM Command signal waveform.	49
Figure 4-7 Factory-installed DB-9.	53
Table 4-6 DB-9 pin assignments.	55
Figure 4-8 Physical layout of Series 48 DB-9.	57
Table 4-7 DB-9 Connector input signal specs.	57
Table 4-8 DB-9 Connector output signal specs. ...	57
Figure 4-9 Remote Keyswitch circuit.	58
Figure 4-10 Remote Interlock circuit.	58
Figure 4-11 Remote Ready output to PLC input.	59
Figure 4-12 Message Output to PLC input.	60
Figure 4-13 Fault Shutdown Output to PLC input.	60
Table 4-9 Model 48-1 general specifications.	67
Table 4-10 Model 48-2 general specifications.	69
Table 4-11 Model 48-5 general specifications.	71
Figure 4-14 Model 48-1 package outline and mounting dimensions, 1 of 2.	74
Figure 4-15 Model 48-2 package outline and mounting dimensions, 2 of 2.	75
Figure 4-16 Model 48-5 package outline and mounting dimensions.	76

Tables and Figures

ing dimensions.	76
Figure 4-17 Model 48-1 packaging instructions.	77
Figure 4-18 Model 48-2 packaging instructions.	78
Figure 4-19 Model 48-5 packaging instructions.	79
Figure 4-20 FLMK-1A (10W fan shroud) packaging instructions.	80
Figure 4-21 FLMK-2A (25W fan shroud) packaging instructions.	81
Table 5-1 Required cleaning materials.	85
Figure 5-1 48 series™ flowchart.	89
Table 5-2 Series 48™ cooling specifications.	91
Table 5.3 48 series™ Input/Output & LED Status Signals.	93
Figure A-1 Typical closed loop setup.	97
Figure A-2 Graph of duty cycle vs. power output before/after C.L. kit installed.	98
Table A-1 C.L general specifications.	99